

# LANpoint XL

## Technical Manual



855M538 Rev. 1.1

# Preamble

This manual contains a detailed description of the product and we have made every effort to make it as accurate as possible. However, this is not a guarantee of the features or the functionality of the product. We reserve the right to modify the contents of this document at any time and without prior notice. Because we at Intelligent Instrumentation are constantly striving to improve this product, we cannot guarantee that previous or subsequent releases of the product will coincide in every respect with the product description given in this manual.

Intelligent Instrumentation assumes no liability for technical inaccuracies, typographic errors or faults in this documentation. Intelligent Instrumentation also assumes no liability for damages, which refer directly or indirectly to the delivery, performance or usage of this material.

The software and hardware designations used in this documentation are in most cases also registered trademarks and are thus subject to law.

Windows is a registered trademark of Microsoft Corporation in the United States and other countries.

This documentation is protected by copyright. Duplication, in whole or in part, is not permitted without prior written approval of Intelligent Instrumentation Incorporated.

<i>Title of documentation:</i>	<i>LANpoint XL Technical Manual</i>
<i>Documentation completed on:</i>	<i>11/03/2005</i>
<i>Version:</i>	<i>V1.1</i>
<i>Manual number:</i>	<i>855M538</i>

© Copyright 2005 by Intelligent Instrumentation Incorporated  
Tucson , Arizona, USA  
All rights reserved

## **Warranty and Repair Policy Statement**

### **General**

Seller warrants that its products furnished hereunder will, at the time of delivery, be free from defects in material and workmanship and will conform to Seller's published specifications applicable at the time of sale. Seller's obligation or liability to Buyer for products which do not conform to above stated warranty shall be limited to Seller, at Seller's sole discretion, either repairing the product, replacing the product with a like or similar product, or refunding the purchase price of the nonconforming product, provided that written notice of said nonconformance is received by Seller within the time periods set forth below:

- a. For all software products, including licensed programs, ninety (90) days from date of initial delivery to Buyer;
- b. For all hardware products (excluding batteries), including complete systems, fifteen (15) months from date of initial delivery to Buyer, subject to the additional conditions of paragraph c) below;
- c. In the event that Buyer's returned product is a Discontinued product and is not repairable for any reason,

Seller may elect to replace it with like or similar product that is, in Seller's sole judgment, the closest equivalent to the returned product. Seller does not warrant that such replacement product will be an exact functional replacement of the returned product.

Further, all products warranted hereunder for which Seller has received timely notice of nonconformance must be returned FOB Seller's plant no later than thirty (30) days after the expiration of the warranty periods set forth above.

These warranties provided herein shall not apply to any products which Seller determines have been subjected, by Buyer or others, to operating and/or environmental conditions in excess of the limits established in Seller's published specifications or otherwise have been the subject of mishandling, misuse, neglect, improper testing, repair, alteration or damage. THESE WARRANTIES EXTEND TO BUYER ONLY AND NOT TO BUYER'S CUSTOMERS OR USERS OF BUYER'S PRODUCT AND ARE IN LIEU OF ALL OTHER WARRANTIES WHETHER EXPRESS, IMPLIED OR STATUTORY INCLUDING IMPLIED WARRANTIES OF MERCHANTABILITY AND FITNESS FOR A PARTICULAR PURPOSE. IN NO EVENT SHALL SELLER BE LIABLE FOR INCIDENTAL, SPECIAL OR CONSEQUENTIAL DAMAGES.

Seller's liability for any claim of any kind shall in no case exceed the obligation or liability specified in this Warranty clause.

### **Technical Assistance and Service**

Seller's warranty as herein set forth shall not be enlarged, diminished or affected by, and no obligation or liability shall arise or grow out of, Seller's rendering of technical advice, facilities or service in connection with Buyer's order of the goods furnished hereunder. Products returned for warranty service, but which are found to be fully functional and in conformance with specifications may be subject to a nominal service charge and return freight charges. Periodic recalibration of products, if required, is the responsibility of Buyer and is not provided under this Warranty.

## Online Support

Online support is available through technical support links on Intelligent Instrumentation's 24-hour World Wide Web site at

<http://www.lanpoint.com>. The site contains information on Intelligent Instrumentation's products, new developments, announcements, application notes, application examples, and other useful information. The site and support areas continue to grow as new products, updates, and features are added.

## Email Support

Intelligent Instrumentation's technical support can be reached via email. When sending an email message, be sure to include complete contact information, the product model/part number with third-party accessory information, and a detailed description of the problem.

Use the following addresses to contact the support group:

### North American Customers

[support@lanpoint.com](mailto:support@lanpoint.com)

### International Customers

[international@lanpoint.com](mailto:international@lanpoint.com)

[int\\_support@lanpoint.com](mailto:int_support@lanpoint.com)

In France: [france@lanpoint.com](mailto:france@lanpoint.com)

In Italy: [italy@lanpoint.com](mailto:italy@lanpoint.com)

In Germany: [germany@lanpoint.com](mailto:germany@lanpoint.com)

## Static Sensitivity

Seller ships all static-susceptible products in anti-static packages. Seller's Warranty as herein set forth shall not cover warranty repair or replacement for products damaged by static due to Buyer's failure to use proper protective procedures when handling, storing, or installing products.

## Trademarks

LANpoint Computers®, LANpoint®, Intelligent Instrumentation® are trademarks of Intelligent Instrumentation, Inc. Other products or brand names are trademarks or registered trademarks of their respective companies.

## Use of Equipment

Intelligent Instrumentation Inc., assumes no responsibility for any direct, indirect or consequential loss or damages resulting from misuse of the equipment or for improper or inadequate maintenance of the equipment or for any such damage or loss resulting from the use of other equipment, attachments, accessories, and repairs at any time made to or placed upon the equipment or any replacement thereof. Furthermore, Intelligent Instrumentation Inc., makes no representations or warranties, either expressed or implied, in connection with the use of the equipment in the event it is improperly used, repaired or maintained.

## **FCC Radio Frequency Interference Statement**

This equipment generates and uses radio frequency energy, and may cause interference to radio or television reception.

Per FCC rules, Part 15, Subpart J, operation of this equipment is subject to the conditions that no harmful interference is caused and that interference must be accepted that may be caused by other incidental or restricted radiation devices, industrial, scientific or medical equipment, or from any authorized radio user.

The operator of a computing device may be required to stop operating his device upon a finding that the device is causing harmful interference and it is in the public interest to stop operation until the interference problem has been corrected.

The user of this equipment is responsible for any interference to radio or television reception caused by the equipment. It is the responsibility of the user to correct such interference

# Warnings and notices

Warnings and notices in this manual are indicated as follows:



This symbol indicates **general information** that helps you to understand how to use the product or the manual.



This symbol warns you of dangers which may lead to **damage to the terminal or system** (e. g. faulty functions, data loss, material damage etc.)



This symbol is used to mark **dangers to health and life** (e. g. possible contact with power supply).

You must observe this information!

This section contains safety notices that must be observed when installing, operating and maintaining the LANpoint XL device.

Within this manual, Intelligent Instrumentation strives to provide all information required when using this device. However, because the device is a versatile product that can be used in many different scenarios, we cannot guarantee that the information contained in this manual will cover every single aspect. Should you require further information or if you have questions or issues needing clarification, please contact your nearest Intelligent Instrumentation agent or representative.

This device meets standard industry safety regulations. It has not been designed for use in life-support systems or critical safety systems where system malfunction can lead to the direct or indirect endangerment of human life.

Installation, maintenance and operation may only be carried out by qualified electrical or electronics engineers or persons trained by Intelligent Instrumentation. The information provided in this manual is intended exclusively to complement existing professional expertise, not to replace it.

# Important safety notices

## Initial operation of the device



### Area of application

The device is not designed for use in life-support systems or critical safety systems where system malfunction can lead to the direct or indirect endangerment of human life. The operator shall take full responsibility for using the device in these situations.



### Choice of location

The ambient conditions at the point of installation must comply with the device's protection class.

The LANpoint XL employs a passive cooling concept whereby the waste heat generated inside the device is emitted from the surface of the housing. For this system to function properly, sufficient fresh air circulation is required. Never install the system in a closed environment where the cooling air is unable to dissipate accumulated heat to the outside.

If the LANpoint XL is not able to draw in fresh cooling air, this may cause overheating and severe damage to the unit. Be sure to comply with the maximum ambient temperature to guarantee correct operation (as specified in *Appendix A: Technical Specifications*).

## Initial operation of the device

### Installation / initial operation



The device is not supplied with a disconnecter (switch) that can be accessed externally. The power supply connector is therefore used as a disconnecter. This must always be easily accessible. If the device is permanently installed, an easily accessible disconnecter (such as a switch or automatic circuit breaker) needs to be additionally installed.

The power supply cables must be laid in accordance with the applicable local installation regulations.

---

Risk of injury: The unit could fall during transit or installation and cause injury. Always enlist the aid of a second person for installing or removing the unit.



The installation and configuration of the operating system should only be carried out by qualified personnel familiar with the system environment.

## Power supply and external peripheral devices



In cases of emergency (such as damage to the power cable or housing, or ingress of liquid or other foreign bodies), the device must be disconnected immediately from the power supply. Contact technical support staff at once.

If the fuse for the integrated power supply blows immediately after being replaced, send the unit for servicing without delay.

Data cables may never be connected or disconnected during an electrical storm.



### Initial operation with external peripheral devices

Before connecting or disconnecting peripheral devices (exception: USB devices), the LANpoint XL must be disconnected from the power supply! (Read chapter 3, section *Connecting/Disconnecting external devices*.) Otherwise, this could seriously damage both the LANpoint XL and the connected devices!

Please ensure that external peripheral devices with their own power supply are switched on at the same time or **after** the LANpoint XL. If this is not possible, please ensure that the LANpoint XL is adequately protected from power leakage caused by an external device.

# Information about your device model

## Never carry out your own repairs

As a rule, never carry out repairs on the device yourself. Always contact Intelligent Instrumentation's technical support and send in your unit for repair if necessary.



The information required by our technical support is given on the type plate located at the back of the unit. This designation contains important technical information on the functions and assembly of your device. Always provide technicians with the entire model designation and serial number.

The type plate provides the following details:

- LANpoint XL 110** '110' is the code for the **LANpoint XL** device with a **10.4"** display size. '112' denotes the **12.1"** display size
- SVGA , VGA or XGA** describes the resolution of the display
- AC or DC** describes the type of power supply; the number following (from 1-9) is a code for the specific power supply type including input voltage

The following characters describe device options:

**H** stands for **Heating**

The second line lists the nominal input voltage for the DC power supply with a nominal current e.g., **24/48 V** with **6.2 A**.

AC power supplies are described with the AC frequency required.

The CPU clock rate is shown next, e.g., **733 MHz**.

The serial number (**S/N**) consists of 11 or 12 digits and includes:

- the Intelligent Instrumentation device code (**20** stands for the LANpoint XL model range)
- as well as the week of manufacture (e.g., CW **31**) and year (e.g., **2005**) of manufacture
- The last six characters (followed by "**S**") are the unique serial number of the terminal.

<b>LANpoint XL</b>	<b>110/SVGA</b>	<b>DC-3</b>
<b>24/48 V</b>	<b>⇄ 3.7 A</b>	<b>733MHz</b>
<b>S/N:</b>	<b>203105</b>	<b>103998 "S"</b>

## Opening and closing the device

If you choose to open the LANpoint XL at your own risk, please make sure you observe the safety instructions from the previous pages.



### Persons authorized to open and close the device

The LANpoint XL may only be opened for the purposes of adding or exchanging modules. Only qualified electrical or electronics engineers or persons trained by Intelligent Instrumentation are authorized to do this.



### Power supply

Prior to opening the device, ensure that the operating system has been shut down correctly and that the device is disconnected from the power supply. If the LANpoint XL is equipped with an optional UPS battery, only open the device when the power LED is off.

### Risk of injury

The unit could fall during transit or installation and cause injury. Always ensure that there are two persons available when installing or de-installing the device.



### On opening and closing the device, pay attention to the following:

Note that even the intrusion of extremely small metallic splinters or small amounts of moisture can put the LANpoint XL out of service. Always open the device in a weather-protected environment that is as dust-free as possible.

The surface of the touch screen should always be kept free of dirt, dust, finger marks and so on to ensure full visibility of the display. Ensure that the touch screen does not get scratched or otherwise damaged, before placing the device face down.

When working on the device, only use the appropriate tools as listed in *Appendix D*. For devices compliant with protection class IP65, you also require a torque wrench to properly close the device.

---

If you open the device, disconnect the cable connections to the front of the display. Follow the instructions on *opening and closing the device* in the assembly guide.

Before closing the device, please ensure that the cable connections to the front of the display have been replaced correctly. Make sure the cables are not unduly stressed or bent.

---



### **Device seal**

The front of the LANpoint XL device has a protective seal glued into its frame. Do not attempt to remove the seal, as this will cause irreversible damage to it and render it unusable.

Before closing the device, ensure the seal is seated properly between the face and the device housing – especially for devices compliant with protection class IP65. Visually check the seal for defects (tears, cuts) and foreign bodies (dirt). If you can tell the seal is damaged, or if you think it may be damaged, contact Intelligent Instrumentations' technical service.

---

### **Replacing the seal on IP65 devices**

Never replace the glued-in seal on devices compliant with protection class IP65 yourself. This will instantly void all present and future guarantee and liability claims.

### Closing the device

The front bezel is attached to the base unit using hexagonal screws (M5 x 20 with an inside diameter of 3 mm). In all devices, these screws must be retightened with a torque wrench. Retighten all the hexagonal screws in a **cross-wise** pattern to the following **torque**: LANpoint XL10,4": 3Nm, LANpoint XL 12,1": 4 Nm.



Tighten both screws in the protective cap and antenna cap to a torque of 2 Nm.

---

Please be aware that any test marks and the guarantee may lose their validity if the device has been improperly operated or opened/closed. For devices compliant with protection class IP65, for example, Intelligent Instrumentation no longer guarantees the safety rating if the device has been improperly opened or closed by persons insufficiently qualified.

# Exchanging and extending modules

Carefully follow the notices on opening and closing the device!

## Fuse failure

If the fuse for the integrated power supply blows immediately after being replaced, send the unit to us for servicing without delay.

## No battery changes!

The LANpoint XL motherboard is powered by a lithium battery fixed to the motherboard. This battery should not be exchanged under any circumstances, as this requires soldering! Should a battery change be necessary, the device must be sent to Intelligent Instrumentation. Changing the battery yourself will instantly void all present and future guarantee and liability claims.

Using an unsuitable battery type or incorrectly installing it may cause the battery to explode.



## Module extension

The LANpoint XL may only be opened for the purposes of adding or exchanging modules. Only qualified electrical or electronics engineers or persons trained by Intelligent Instrumentation are authorized to do this.

When adding and exchanging modules, only use components approved by Intelligent Instrumentation for use in the LANpoint XL. Before installing a component, please contact Intelligent Instrumentation to ensure that the desired module can be exchanged or installed.

### **Module extension**

When installing expansion modules, proceed with utmost caution. Any damage caused while installing or replacing modules will instantly void all present and future guarantee and liability claims.

### **Damage to the computer system**

To avoid damage to the motherboard and/or other computer components, only install modules in the designated slots.



Never physically touch the motherboard or any electrical components in a non-ESD-protected area, as this may cause damage to the motherboard. Before physically touching motherboards or electrical components, make sure that you are working within an ESD-protected area.

---

### **System overload**

To avoid system overloads, check the total acceptable load for all of the installed components.

Ensure that the input power for each device is within the permitted threshold (see technical specifications for the corresponding device). Read Appendix A: *Technical specifications/Power supply: Maximum power available for peripheral devices.*

# Electromagnetic compatibility

## EMC



This product has been tested and is compliant with the values specified by Section 15 of the FCC regulations and EN 55011 Class A. These values have been suggested in order to ensure adequate protection against interference for devices operated in business and industrial areas.

The LANpoint XL is a Class A device. The product works within the specified limits and may cause radio interference when used in residential applications. In such cases, the user may be required to finance and carry out the necessary modifications.

## Environmental protection



### Disposal

Dispose system components and other supplied components according to the legislation in force in your country and, whenever possible, in an environmentally friendly way.



# Table of contents

---

<b>Important safety notices .....</b>	<b>I-XI</b>
<b>EMC / Environmental protection .....</b>	<b>XII</b>
<b>Important safety notices .....</b>	<b>VII</b>
<b>1. Introduction.....</b>	<b>1</b>
1.1. General.....	1
1.2. About this manual.....	1
1.3. The LANpoint XL models:.....	2
1.4. The LANpoint XL equipment .....	2
<b>2. Unpacking the device.....</b>	<b>4</b>
2.1. Scope of delivery .....	4
2.2. Packaging.....	4
2.3. Abbreviations used for devices and accessories .....	5
2.4. Returning your device.....	5
<b>3. Mounting the device / Assembly kits.....</b>	<b>6</b>
3.1. Mechanical dynamic loading .....	7
3.1.1. Mobile application without vibration insulation (tuned to a high frequency) .....	7
3.1.2. Mobile application with passive vibration insulation (tuned to a low frequency).....	8
3.1.3. Determining natural frequencies .....	13
3.2. Cooling .....	14
3.3. Power supply .....	15
3.3.1. AC power pack.....	15
3.3.2. DC power pack .....	16
3.3.3. Installing connecting cables .....	17
3.3.4. Vehicle applications (such as forklifts) .....	17
3.4. Connecting / disconnecting external devices.....	19
3.4.1. Connector bay.....	20
3.5. Cable cover (splash guard) .....	21
3.5.1. Protection class IP65 .....	21
3.5.2. Protection class IP54 .....	22
3.6. Removing the protective film (display).....	24
<b>4. Initial operation.....</b>	<b>25</b>

4.1.	Powering up the LANpoint XL .....	25
4.2.	LANpoint XL Operating controls.....	26
4.2.1.	Front controls (standard) .....	28
4.2.2.	Front controls (extended) .....	29
4.3.	Operating states.....	30
<b>5.</b>	<b>Maintenance .....</b>	<b>31</b>
5.1.	Cleaning the touch screen .....	31
<b>6.</b>	<b>BIOS .....</b>	<b>32</b>
6.1.	General .....	32
6.2.	BIOS boot messages .....	33
6.2.1.	Startup screen BIOS system check.....	33
6.2.2.	Startup screen BIOS system configuration.....	34
6.3.	Starting BIOS setup .....	35
6.3.1.	Setup pages of the LANpoint XL BIOS.....	35
6.4.	Power On Self Test (POST).....	46
6.5.	BIOS hot keys.....	47
6.5.1.	Loading the standard settings .....	47
6.5.2.	Warm start.....	47
6.6.	BIOS Update.....	48
6.6.1.	General Information.....	48
6.6.2.	Procedure.....	48
<b>7.</b>	<b>LANpoint XL Operation and Configuration.....</b>	<b>50</b>
7.1.	The Windows CE.NET 4.2 operating system .....	50
7.2.	Initial Power-Up Sequence .....	51
7.2.1.	Configuring the TCP/IP Parameters .....	51
7.2.2.	File Transfer Methods .....	52
7.2.3.	Accessing Shared Directories .....	52
7.2.4.	Autorun Feature and Creating a shortcut on the desktop.....	53
7.2.5.	Saving the content in the Windows CE.NET registry.....	53
<b>8.</b>	<b>External peripheral devices .....</b>	<b>54</b>
8.1.	Keyboard .....	54
8.1.1.	SMALL keyboard.....	55
8.2.	Mouse .....	56
8.3.	Serial interfaces .....	57
8.3.1.	Resources .....	57
8.3.2.	COM1 options .....	57
8.3.3.	COM2 options .....	58
8.3.4.	Drivers.....	58
8.3.5.	Serial interface barcode scanners using Wedgece.exe.....	59
8.3.6.	Tips & tricks.....	60

8.4.	Plug-in cards .....	61
8.4.1.	Resources.....	61
8.4.2.	Installation.....	61
8.4.3.	Riser card with 1x PCI .....	62
8.4.4.	Drivers .....	62
8.5.	Automatic switch-off and heating.....	63
8.5.1.	Modes of operation .....	63
8.5.2.	Resources.....	64
8.5.3.	Automatic switch-off.....	65
8.5.4.	Program flowchart for automatic switch-off / automatic switch-off & automatic heating .....	66
8.6.	MPCCOM (DOS only) .....	68
<b>9.</b>	<b>Appendix A: Technical specifications .....</b>	<b>70</b>
9.1.	System equipment.....	70
9.1.1.	Mechanical.....	70
9.1.2.	Motherboard.....	71
9.1.3.	LCD / CRT interface.....	73
9.1.4.	Touch interface (optional) .....	73
9.1.5.	Network interface .....	74
9.1.6.	ADC/MDC interface (optional).....	74
9.1.7.	Cardbus interface.....	74
9.1.8.	Power supply (The device model is displayed on the device type plate) .....	75
9.1.9.	Maximal power available for peripheral devices.....	76
9.1.10.	Power supply fuses.....	77
9.1.11.	Environmental conditions .....	78
9.1.12.	Licenses.....	78
9.2.	System resources - Part 1 .....	79
9.3.	System resources - Part 2 .....	80
9.4.	Resistance of the touch screen .....	81
9.4.1.	Resistance to chemical substances .....	81
9.4.2.	Pencil hardness test ASTM D 3363.74 .....	82
9.5.	System dimensions .....	83
9.5.1.	LANpoint XL 10,4" SVGA dimensions.....	83
9.5.2.	LANpoint XL 12,1" dimensions.....	86
9.6.	VESA holes .....	89
<b>10.</b>	<b>Appendix B: Pin configuration .....</b>	<b>90</b>
10.1.	External connectors.....	90
10.1.1.	AC voltage supply connector .....	92
10.1.2.	DC voltage supply connector .....	93
10.1.3.	Keyboard and Mouse.....	96
10.1.4.	USB .....	96
10.1.5.	Serial port COM1 .....	97
10.1.6.	Serial port COM2 .....	97

10.1.7.	Network connector .....	99
10.1.8.	CardBus connector.....	100
10.2.	Internal connectors, motherboard Rev. 5.10.....	101
10.2.1.	Input voltage connector .....	102
10.2.2.	Ignition signal connector.....	102
10.2.3.	Heating power connectors.....	102
10.2.4.	Serial port COM2.....	103
10.2.5.	Audio interface .....	103
10.2.6.	IDE plug-in connector.....	104
10.2.7.	CompactFlash plug-in connector.....	105
10.2.8.	LCD connector .....	106
10.2.9.	Front keyboard connector.....	107
10.2.10.	Inverter connector .....	107
10.2.11.	Inverter connector .....	107
10.2.12.	Riser Card connector .....	108
10.3.	Internal connectors, riser card.....	109
10.3.1.	PCI connectors (CC) .....	110
<b>11.</b>	<b>Appendix C: Jumpers .....</b>	<b>112</b>
11.1.	Warnings.....	112
11.2.	Standard jumper settings .....	112
11.3.	Jumper layout view, motherboard.....	113
11.3.1.	Touch configuration .....	114
11.3.2.	Battery.....	114
11.3.3.	Touch enable.....	114
11.3.4.	CompactFlash configuration.....	115
11.3.5.	COM1 configuration .....	115
11.3.6.	Ethernet configuration .....	116
11.3.7.	LCD configuration.....	116
11.3.8.	External shield connection.....	116
<b>12.</b>	<b>Appendix D: Tools .....</b>	<b>117</b>
12.1.	Warnings.....	117
12.2.	LANpoint XL Toolkit .....	118
12.3.	Mounting bracket toolkit.....	119
<b>13.</b>	<b>Appendix E: Common mistakes in usage.....</b>	<b>120</b>
13.1.	Power supply .....	120
13.2.	Powering up/powering down.....	120
13.3.	Cable cover.....	120
13.4.	Installation.....	121
13.5.	Mobile vehicle applications .....	121
13.6.	Using the touch screen .....	122
13.7.	Use/storage in extreme temperatures.....	122

13.8. Disposal/environment .....	122
<b>14. Appendix F: Return packing slip.....</b>	<b>123</b>
<b>Index.....</b>	<b>124</b>

# List of figures

---

<b>Figure 3.1:</b> Example for an elastic table-top fixing .....	9
<b>Figure 3.2:</b> LANpoint XL with a cable cover .....	21
<b>Figure 3.3:</b> LANpoint XL without a cable cover .....	22
<b>Figure 3.4:</b> LANpoint XL with a cable cover .....	23
<b>Figure 4.1:</b> LANpoint XL with a 12.1" display and 25 buttons .....	26
<b>Figure 6.1:</b> BIOS system check .....	33
<b>Figure 6.2:</b> Startup screen BIOS system configuration .....	34
<b>Figure 6.3:</b> "CMOS SETUP UTILITY" screen.....	35
<b>Figure 6.4:</b> "Standard CMOS Features" screen .....	36
<b>Figure 6.5:</b> "IDE Primary Master" screen .....	36
<b>Figure 6.6:</b> "IDE-Primary Slave" screen .....	37
<b>Figure 6.7:</b> "Video" screen .....	37
<b>Figure 6.8:</b> "Halt On" screen .....	38
<b>Figure 6.9:</b> "Advanced BIOS Features" screen .....	38
<b>Figure 6.10:</b> "First Boot Device" screen .....	39
<b>Figure 6.11::</b> "Second Boot Device" screen .....	40
<b>Figure 6.12:</b> "Third Boot Device" screen .....	40
<b>Figure 6.13:</b> "Advanced Chipset Features" screen .....	41
<b>Figure 6.14:</b> "Panel Type" screen .....	42
<b>Figure 6.15:</b> "Integrated Peripherals" screen .....	42
<b>Figure 6.16:</b> "Power Management Setup" screen .....	43
<b>Figure 6.17:</b> "PnP/PCI Configurations" screen.....	44
<b>Figure 6.18:</b> "PC Health Status" screen .....	44
<b>Figure 6.19:</b> "Frequency/ Voltage Control" screen .....	45
<b>Figure 8.1:</b> SMALL keyboard mounted on the LANpoint XL .....	55
<b>Figure 9.1:</b> Program flowchart part 1 .....	66
<b>Figure 9.2:</b> Program flowchart part 2 .....	67
<b>Figure A.1:</b> LANpoint XL/110 SVGA front view.....	83
<b>Figure A.2:</b> LANpoint XL/110 SVGA side view .....	84
<b>Figure A.3:</b> LANpoint XL/110 SVGA top view .....	85
<b>Figure A.4:</b> LANpoint XL/112 front view.....	86

<b>Figure A.5:</b> LANpoint XL/112 side view .....	87
<b>Figure A.6:</b> LANpoint XL/112 top view .....	88
<b>Figure A.7:</b> LANpoint XL/110 with VESA holes .....	89
<b>Figure B.1:</b> External connectors, AC version.....	90
<b>Figure B.2:</b> External connectors, 24/48 VDC 60 W version.....	90
<b>Figure B.3:</b> External connectors, 24/48 VDC 100 W version.....	91
<b>Figure B.4:</b> External connectors, 12 VDC 100 W version.....	91
<b>Figure B.5:</b> Outside view of the AC power supply connector.....	92
<b>Figure B.6:</b> Outside view of the DC power supply connector .....	93
<b>Figure B.7:</b> Cable diagram of the +12 VDC device's supply connection .....	94
<b>Figure B.8:</b> Cable diagram of the +24 / +48 VDC device's supply connection .....	95
<b>Figure B.9:</b> Internal connectors, motherboard rev. 03.2003 .....	101
<b>Figure B.10:</b> Internal connectors, riser card 1 x PCI.....	109
<b>Figure C.1:</b> Jumper layout, motherboard Rev. 5.20 03.2003.....	113
<b>Figure D.1:</b> LANpoint XL toolkit .....	118
<b>Figure D.2:</b> Mounting bracket toolkit.....	119



# 1. Introduction

## 1.1. General

Thank you for selecting Intelligent Instrumentation's LANpoint XL.

The LANpoint XL is a multi-functional PC designed for stationary and mobile use. Thanks to its robust design (using an aluminium housing), the device provides effective protection against mechanical, electrical and chemical influences and extreme ambient temperatures. Its design without an external fan is intended for low-maintenance requirements.

The particular advantage offered by the LANpoint XL is the extreme diversity of functions combined with its compact design. Thanks to the integrated mount, the device requires minimal space for its installation.

Using high-quality components for the display and touch screen, the LANpoint XL pairs excellent image quality with the simplest operability.

Modern displays as for example 10,4" VGA, 10,4" SVGA, 12,1" SVGA and 12,1" XGA meet all requirements in terms of readability and resolution. The manual brightness control is used to improve visibility in poorly lit environments and adjust the display to different lighting conditions.

Two serial interfaces and two USB 1.1 ports are available to connect a whole range of peripheral devices such as barcode scanners, printers and electronic scales. A PCI adapter and PC card slot make it possible to use wireless networks, GPS, GSM and other functions.

This technical manual describes the LANpoint XL with a Rev. 5.20 03.2003 motherboard.

## 1.2. About this manual

This manual has been designed to make using the LANpoint XL as simple as possible and provide qualified assistance if problems occur. Among other things, this manual provides a description of device operation, the operating system and internal and external peripheral units.

You will find more in-depth information on each unit organized according to functional modules, such as PC card slot, information on the mode of operation, required hardware resources, drivers etc.

And for all those who want to know more, the appendices contain yet more detailed information on this device.

### 1.3. The LANpoint XL models:

The information in this handbook applies to both the:

- LANpoint XL with 10.4" display and the
- LANpoint XL with 12.1" display

Differences between the devices are expressly marked as such in this manual (such as system dimensions).

### 1.4. The LANpoint XL equipment

The LANpoint XL runs on a Pentium III/Celeron-compatible VIA Eden 400 MHz or 733 MHz processor.

It uses a VIA PL133 system chipset. This chipset controls the memory, all mass storage and USB ports.

Standard I/O functionality is also provided. This comprises two serial ports, keyboard and mouse control and a clock function.

The memory can be expanded with SO-DIMM modules with over 144 pins and up to 512 MB SDRAM.

The BIOS (Basic Input Output System) is integrated into a 256 KB Flash memory module. This BIOS can be easily updated on the system as soon as each new version becomes available.

The Savage4 2D/3D graphics accelerator integrated into the chipset takes over the task of controlling the various displays. The computer RAM provides the memory for video processing. This is referred to as "shared memory". You can define the size of the graphics memory in the BIOS.

An AC97-compatible module is optionally available for processing audio.

A Realtek RTL8139 network controller with a capacity of 10/100 Mbit provides the network connection. The drivers required for MS-DOS, Microsoft Windows 9x/NT4.0, Embedded/2000/XP and Linux operating systems are also available.

An analog touch controller with 12-bit resolution for resistive panels handles touch screen operation.

A variety of power packs can be integrated to supply the LANpoint XL with power. These currently include an AC power pack for 115/230 V AC as well as electrically isolated DC power packs with a nominal input voltage of 24/48 V DC and 12 V DC.

An automatic switch-off is optionally available for the integrated power supply. Heating can also be integrated for applications in areas with temperatures below 0 C.

The UPS battery (with DC power supply) ensures that the computer will continue to operate even when the voltage temporarily drops or power is lost in the vehicle (such as when replacing a forklift battery), or when an active LANpoint XL is transported from one vehicle to another.

Ultra-short PCI plug-in cards can be integrated via the optional, internal plug-in card slot.

Please observe the maximum power available for peripheral devices. Read Appendix A: *Technical specifications/Power supply: Maximum power available for peripheral devices*.

The LANpoint XL is compatible with the conventional operating systems and application programs.



In the course of continuously improving our products, we at Intelligent Instrumentation reserve the right to replace any of the currently available special options with new ones. If necessary, you are therefore requested to contact your sales office.

## 2. Unpacking the device

### 2.1. Scope of delivery

The delivery includes at least the following:

- The LANpoint XL
- The ordered assembly set
- One cable cover with strain relief rail (standard = IP54; optional = IP65)
- One DC or AC connecting cable
- One SDK and driver CD per delivery
- One printed manual per delivery



Please verify the delivery contents immediately on receipt!

### 2.2. Packaging

The packaging material has been selected to optimally protect your device while simultaneously offering the best possible ecological compatibility. We therefore kindly request that you store the original packaging material or ensure it is used for another suitable purpose such as transporting the unit or returning shipment.



If you repack the device, please ensure that the cling wrap in the cardboard frame is oriented correctly to the front of the device so that they can provide the proper protection.

## 2.3. Abbreviations used for devices and accessories

Please note that to save space on the LANpoint XL and supplied accessories, the following abbreviations have been used:

+	DC+
-	DC-
Ign	Ignition

## 2.4. Returning your device

Due care was exercised when putting together the contents of your delivery and dispatching your device. Nevertheless, if you still have cause for complaint, please complete the form included in the appendix.

Should you need to return the device, please use the original packaging.

### 3. Mounting the device / Assembly kits

The LANpoint XL can be mounted in a variety of ways:

- The LANpoint XL can be placed horizontally on a desk or affixed to vehicle and vehicle consoles
- Wall mounts are also available for fixing the LANpoint XL to machines or on operating panels

Depending on the vibration resilience and pivoting demands, mounting brackets, rotating bases and RAM mount components can be used to attach the device.

Please contact your Intelligent Instrumentation sales office to find out more about the whole range of mounting options.



#### **Risk of injury**

The unit could fall during transit or mounting and cause injury. Always ensure that there are two persons available when mounting or removing the device.



Please observe the mounting instructions included with assembly kit when installing your LANpoint XL.

Please retain the mounting instructions.

Pay careful attention to the "Important safety notices" included at the start of this manual.

## 3.1. Mechanical dynamic loading

Since the LANpoint XL is a weighted structure, dynamic mechanical effects invariably occur. The main components of the unit have been damped. However, changing conditions at the point of installation may result in operating states where additional anti-vibration measures are required.

### 3.1.1. Mobile application without vibration insulation (tuned to a high frequency)



The LANpoint XL oscillatory system with mounting bracket and additional fixings should be designed to be as stiff as possible.

This spring-mass system is stimulated by periodic oscillations and random vibrations from its environment. The system reacts with natural oscillations, the amplitudes of which can be up to 20 times greater than the excitation amplitudes (resonance effects). The aim is therefore to avoid exciting the natural frequencies or, at least provide that they lie far above the range of the excitation amplitudes.

For an initial assessment, you can test the device by hand. Gently (!) excite the system by nudging it with your hand. If the LANpoint XL begins visibly oscillate and if the vibrations take a long time to die out, it is probable that the natural frequency is too low. In this case, we recommend reinforcing the fixing points where maximum moments of flexion apply using, for example, rigid sections.

Practically speaking, natural frequencies above 100 Hz will not cause problems. However, natural frequencies below 50 Hz are likely to lead to damaging amplitudes during resonance. As a result, fatigue fractures may occur along the outer mounting parts or on the internal electronic components, or for cables to become disconnected.

### 3.1.2. Mobile application with passive vibration insulation (tuned to a low frequency)



The system can be tuned to a low frequency by installing a flexible bearing.

For example, the mounting bracket could be fastened to elastomer springs or rubber buffers.

The total spring constant should ideally be dimensioned to ensure that the natural frequency of the system lies below the lowest excitation frequency. All excitations greater than 1.4 times the natural frequency are dampened by a counter-phase effect. This is practically impossible, if you consider that excitation accelerations within the range of around 10 Hz to 200 Hz and more may occur. Furthermore, the LANpoint XL could begin to tilt due to the soft spring. And at resonance, the display would appear to become blurred.

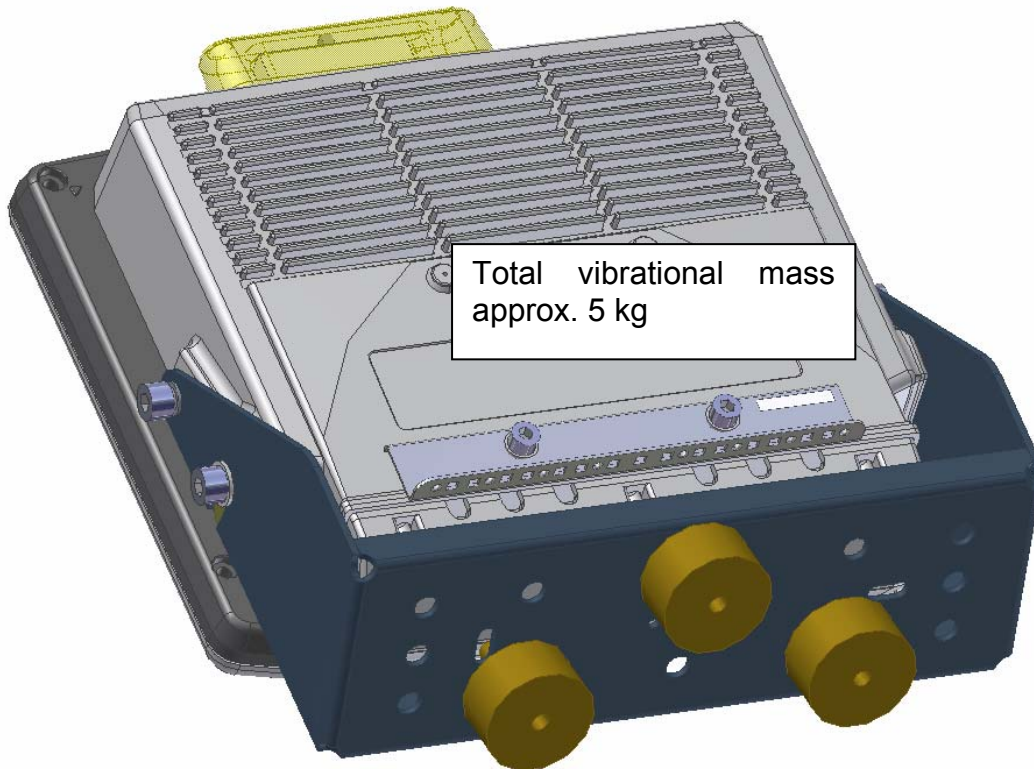
Based on our experience, we have found that the natural frequencies of unsprung forklift trucks lie between 15 Hz and 25 Hz. Even though the elastic bearing still has a single low resonance frequency, the higher excitation frequencies can be well to extremely well suppressed.

#### 3.1.2.1. Example for dimensioning an elastic bearing with mounting bracket for mobile application in accordance with Fig. 2a

The LANpoint XL is screwed tight in a mobile position. Elastomer springs should be installed between the back of the mounting bracket and the assembly surface in the vehicle so that the depth can be adjusted .

The point of resonance for the greatest deflection should lie at 20 Hz.

- a.) Which elastomer springs are suitable?
- b.) What insulating effects can be expected for different excitation frequencies?



#### Installation Example

LANpoint XL with mobile mounting clamp

3 elastomer springs

Diameters 30 to 40 mm, 20 to 30 mm high

Natural rubber

**Figure 3.1:** Example for an elastic table-top fixing

**Approximate solution for a)**

By rearranging  $\omega^2 = c / m$ , we can determine the spring constant:

$$c \cong \frac{4\pi^2}{1000} \cdot m \cdot f_n^2 \approx 0,039 \cdot m \cdot f_n^2$$

whereby  $m$  oscillatory mass in kg = 5 kg  
 $f_n$  natural frequency in Hz = 20 Hz  
 $c$  spring constant in N/mm = **78 N/mm**

This model applies to the oscillatory mass at the device's centre of gravity. The centre of gravity lies approximately 120 mm above the base of the assembly bracket. To determine the spring constant for an individual elastomer spring, the lever conditions and arrangement of the springs (here in a triangle) must also be considered.

First of all, each of the three elastomer springs connected in parallel has to deliver one third of the total spring constant, that is,  $78 \text{ N/mm} / 3 = 26 \text{ N/mm}$  each.

To simplify matters, of the six possible degrees of freedom we will only consider those with the greatest deflection in the case of the LANpoint XL. In other words, we will horizontally observe the display as it oscillates towards or away from us (a combination of rotational and longitudinal oscillation).

Comparative measurements for precisely the arrangement displayed in Fig. 2a show that the individual spring must be stiffer by a factor of 22.5: The spring constant of the purchased single spring should be close to  $26 \text{ N/mm} \times 22.5$  or 585 N/mm.

The next step is to look through manufacturer's datasheets (such as those from gmt-gmbh.de or Lord Rubber Products, [www.lord.com](http://www.lord.com)) to find the right types of elastomer springs and rubber buffers. Here we have decided to use springs with an M8 thread and cylindrical body made of natural rubber (NR). With a diameter of 40 mm and a height of 30 mm, we arrive at the following pressure load:

$$1711 \text{ N} / 3 \text{ mm} = 570 \text{ N/mm for high Shore hardness A} = 70.$$

This value roughly corresponds with the specifications. What would that mean for natural frequency?

$$f_n \approx 5,03 \cdot \sqrt{\frac{c}{m}}$$

whereby  $m$  oscillatory mass in kg = 5

$f_n$  natural frequency in Hz

$c$  total spring constant in N/mm  
 $= 570 \cdot 3 / 22.5 = 76$

The theoretical natural frequency would be 19.6 Hz. This theoretical value corresponds to the natural frequencies measured in practice of 20 Hz  $\pm$  5 Hz.

**Field tests** conducted with the elastomer springs selected in this way are essential if we want to proceed and verify whether the LANpoint XL detrimental deflections (of approx. 19.6 Hz) are acceptable when resonance occurs.

Further steps for optimisation:

- If it turns out that the LANpoint XL resonance deflections could be greater, the natural frequency can be reduced.
- However, if the resonance deflections are too high (10 mm and more), the natural frequency should be increased. In our example, elastomer springs with a diameter of 40 mm instead of 30 mm would be appropriate.

The number, form, material type and arrangement of the elastomer springs can be used to control the natural frequency. As a rule, rubber buffers with vulcanized fittings are used.

In this case, the natural frequency should be changed with due care because of the following dependency:

$$x_n \cong \frac{1}{f_n^2}$$

whereby  $x_n$  resonance deflection



Pure tensile loading on the rubber buffers should not be permitted, as the elastomer will tear easily.

**Approximate solution for b)**

A so-called transmission function can be used for an exact calculation. However, we will not detail this function here. The following equation is based on this transmission

$$Insulation\_factor \cong \left( 1 - \frac{1}{|1 - \lambda^2|} \right) \times 100\%$$

function (very small damping factors of approx. 0.01) and is good for making estimates:

whereby  $\lambda$  = excitation frequency / natural frequency

for  $\lambda > 1$ , the transmission function is used in the case of  $\lambda \leq 1$ .

Excitation frequency	Natural frequency	$\lambda$	Degree of insulation
10 Hz	20 Hz	0.5	-33 %
20 Hz	20 Hz	1	Resonance, approx. -500 % and greater!
Approx. 28 Hz	20 Hz	$\sqrt{2}$	0
40 Hz	20 Hz	2	67 %
60 Hz	20 Hz	3	88 %
80 Hz	20 Hz	4	93 %

**Table: Degree of insulation**

From the table, we can clearly expect very good insulation for excitation frequencies that are twice as high as the system's natural frequency. The table also demonstrates the costs of achieving this, namely that all excitation frequencies below the natural frequency are amplified – with a maximum when resonance occurs.

**Implication for designing computer mounts:**

- If high energy excitation frequencies mainly occur at or below the natural frequency there is no need to use spring mounting for the LANpoint XL. High energy excitation frequencies at or below the natural frequency can be found, for example, in a vehicle chassis tuned to a low frequency.

- If, however, the high energy excitation frequencies predominantly lie above the natural frequency it is recommendable to use passive vibration insulation for the computer. High energy excitation frequencies above the natural frequency can, for example, be caused a forklifts' console design with a distinctive natural frequency over approx. 50 Hz as well as by unbalanced machines with relatively constant and correspondingly high operating speed.

### 3.1.3. Determining natural frequencies

There are several ways of determining a system's natural frequencies such as:

- Taking field measurements with oscillation sensors (this is an exceptionally intensive process, but produces exact results for all spatial axes)
- Calculating the known static spring deflection using the following quantity equation (minimum amount of work taking measurements, and very good approximation)

$$f_n \approx \frac{15,8}{\sqrt{x_{st}}}$$

whereby  $f_n$  natural frequency in Hz

$x_{st}$  static spring deflection in mm  
= deflection of the centre of gravity in the direction of the gravitational force



Further technical Information can be found in the product documents produced by the elastomer spring manufacturers.

## 3.2. Cooling

The LANpoint XL employs a passive cooling concept whereby the waste heat generated inside the device is emitted from the surface of the housing. For this system to function properly, sufficient fresh air circulation is required.

Never install the system in a closed environment where the cooling air is unable to dissipate accumulated heat to the outside.



If the LANpoint XL is not able to draw in fresh cooling air, this may cause overheating and severe damage to the unit. Be sure to comply with the maximum ambient temperature to guarantee correct operation (as specified in *Appendix A: Technical Specifications*).

### 3.3. Power supply

An integrated, electrically isolated AC/ DC power pack is available for the LANpoint XL. The power pack is designed to fulfil the requirements for the full range of operating temperatures of a LANpoint XL with standard extension modules. In a system with a 400 MHz CPU, 64 MB of RAM, a hard drive, a 10.4" display and an external keyboard, this leaves approx. 20 W for plug-in cards and/or external devices.

#### 3.3.1. AC power pack

An integrated, electrically isolated AC power pack is available for the LANpoint XL. This automatically adapts to voltages between 115 VAC or 230 VAC (50-60 Hz)

Its maximum output is 60 W.

Power is connected to the bottom of the device via a standard plug for non-heating devices.



Ensure that there is a suitable disconnecting device such as a power switch or circuit breaker in the power supply circuit. Ensure that the disconnecting device isolates all supply voltage lines. See Appendix B: *Pin configurations*.

### 3.3.2. DC power pack

Three different DC power packs, each fully integrated and electrically isolated, are available for the LANpoint XL:

- Direct current power pack with 18-60 VDC input voltage, maximum output: 60 W
- Direct current power pack with 18-60 VDC input voltage, maximum output: 100 W
- Direct current power pack with 9-16 VDC input voltage, maximum output: 100 W

100 W power packs are required for the heating option.

Power is connected on the bottom of the unit using a Phoenix Contact plug.

In DC applications the LANpoint XL must only be connected to a SELV<sup>1)</sup> (Safety Extra Low Voltage) circuit.



Ensure that there is a suitable disconnecting device such as a power switch or circuit breaker in the power supply circuit. Ensure that the disconnecting device isolates all supply voltage lines. See Appendix B: Pin configurations.

Furthermore, the DC+ - connecting cables must be protected by a fuse (30 AT max). The ignition connecting cables must be protected by the following kind of fuse: 5 x 20 mm T 125 mA L/250 V, Wickmann 195-125 mA/250 V, for example.

<sup>1)</sup> The SELV circuit is a secondary circuit that is designed and protected that its voltages do not exceed a safe value during normal and single fault conditions.

### 3.3.3. Installing connecting cables

Use the connecting cables supplied with the LANpoint XL to connect the equipment to the power supply.

Make sure that the cables connected to the power supply are laid without kinks and are protected appropriately.

### 3.3.4. Vehicle applications (such as forklifts)

Pay special attention to the various electrical potentials when installing the unit on a vehicle (such as a forklift). In the LANpoint XL, the logic ground and the shield ground are firmly linked.



The “logic ground” is the earth line (GND) for all of the internal electrical components, such as the hard drive and the CPU.

Cable shielding, the housing and the ground conductor (in AC-powered units) are connected to the shield ground.

Carefully read the following warnings:



Never connect a 12 VDC unit to a 24/48 VDC vehicle! The device model is written on the device type plate and on the external connector bar.

Some forklifts have a frame that is connected to DC+. Therefore, the LANpoint XL frame is also DC+. However, if you use peripheral devices that supply DC- to the LANpoint XL via an interconnector (such as a DC- serial interface), this will cause a short circuit. This will inevitably lead to malfunctions or even a total system failure.

In DC-powered devices, always attach ring tongue on the supply voltage cable to the ground bolt situated on the connector bay. See Appendix B: *Pin configurations/External connectors*



The position of the ground bolt on the LANpoint XL



The other end of the yellow-green supply voltage cable has to be connected to the vehicle's chassis.

Make sure that the LANpoint XL connecting cable is terminated as close to the battery as possible. Connecting the LANpoint XL to large electrical loads, such as converters for the forklift motor may result in random restarts, malfunctions and/ or irreparable equipment damage to the system.

If you want to connect devices fed by other power sources to the LANpoint XL, such as certain PS/2-Wedges, printers and so on, make sure to power up the peripheral devices at the same time or after the LANpoint XL. Otherwise, you may encounter start-up problems, malfunctions or even irreparable damage to your system.

### 3.4. Connecting / disconnecting external devices

Always power down the LANpoint XL before:

- Connecting or disconnecting external devices (for example, scanner or keyboard) to the LANpoint XL
- Connecting the LANpoint XL to a network

All connections and interfaces on the LANpoint XL are located at the bottom of the unit.



Power down the LANpoint XL before connecting or disconnecting peripheral devices (except USB devices). Otherwise, both the LANpoint XL and the connected devices may be damaged!

Switch on external peripheral devices with their own power supply at the same time as the LANpoint XL or **after**. If this is not possible, make sure that the LANpoint XL is adequately protected from power leakage coming from the external device.

**Always power down the LANpoint XL as follows:**

- Remove the cable cover
- If your LANpoint XL has a DC power supply and automatic switch-off, shut down the device using the ignition input.
- If your device has an AC power supply and automatic switch-off, shut it down using the power button.
- Isolate the DC or AC supply voltage (pull the plug). The position of the plug is shown in *Appendix B: Pin configuration*.

Only when the power LED has extinguished is the LANpoint XL powered down.

**Power up the LANpoint XL**

Only power up the LANpoint XL when all devices have been connected and the LANpoint XL has been properly closed (remember the cable cover!).

**Otherwise, you may damage the LANpoint XL!**

**3.4.1. Connector bay**

Also see Appendix B: *Pin configurations*.

### 3.5. Cable cover (splash guard)



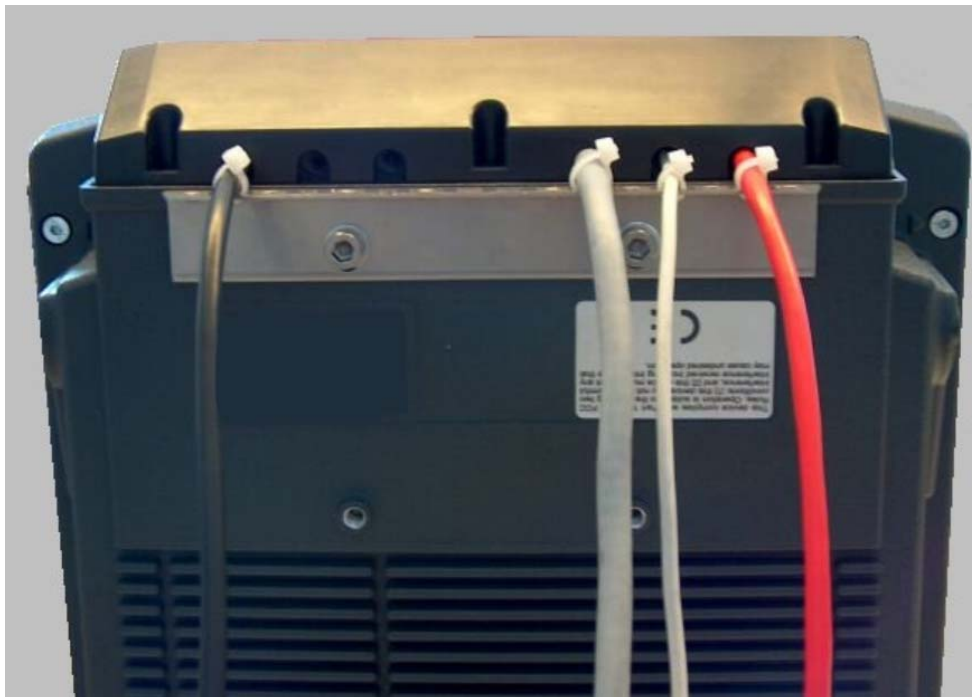
For safety reasons, the supplied cable cover for the external ports must be installed prior to using the LANpoint XL.

#### 3.5.1. Protection class IP65



In order to comply with protection class IP65, please use the optionally available IP65 assembly kit from Intelligent Instrumentation. Please observe the installation instructions included with this assembly kit.

After completing the installation, fasten the cables to the strain relief rail using the enclosed cable ties.

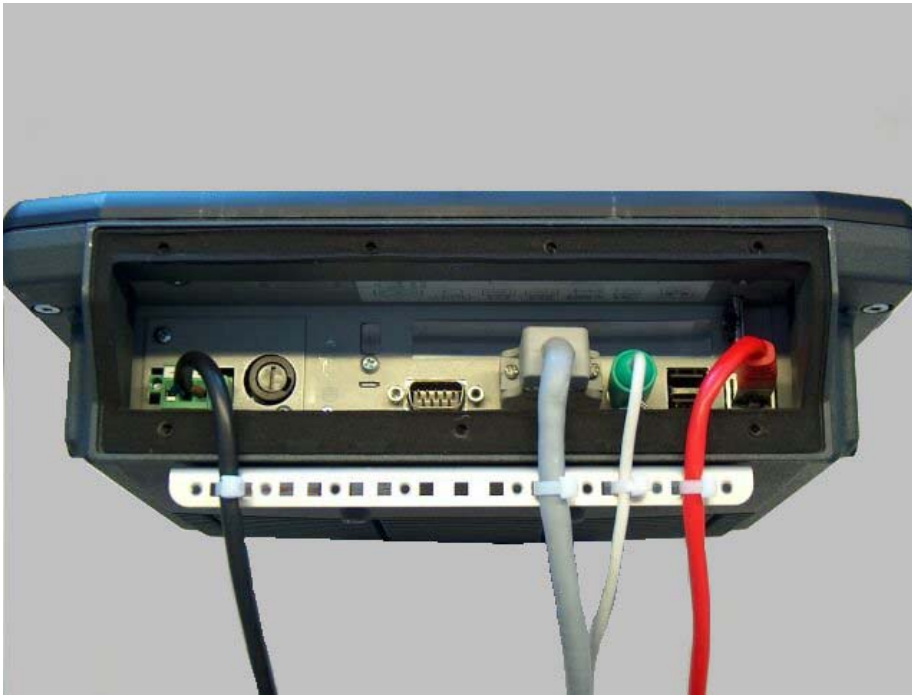


*Figure 3.2: LANpoint XL with a cable cover*

### 3.5.2. Protection class IP54

To ensure that the LANpoint XL continues to conform to this protection category, proceed as follows:

1. Place the cables connected to and from the device next to each other. Avoid crossing the cables.
2. Attach the cables to the strain relief rail using the enclosed cable ties. Ensure that the cables are attached exactly where the cable cover's cable opening is located.

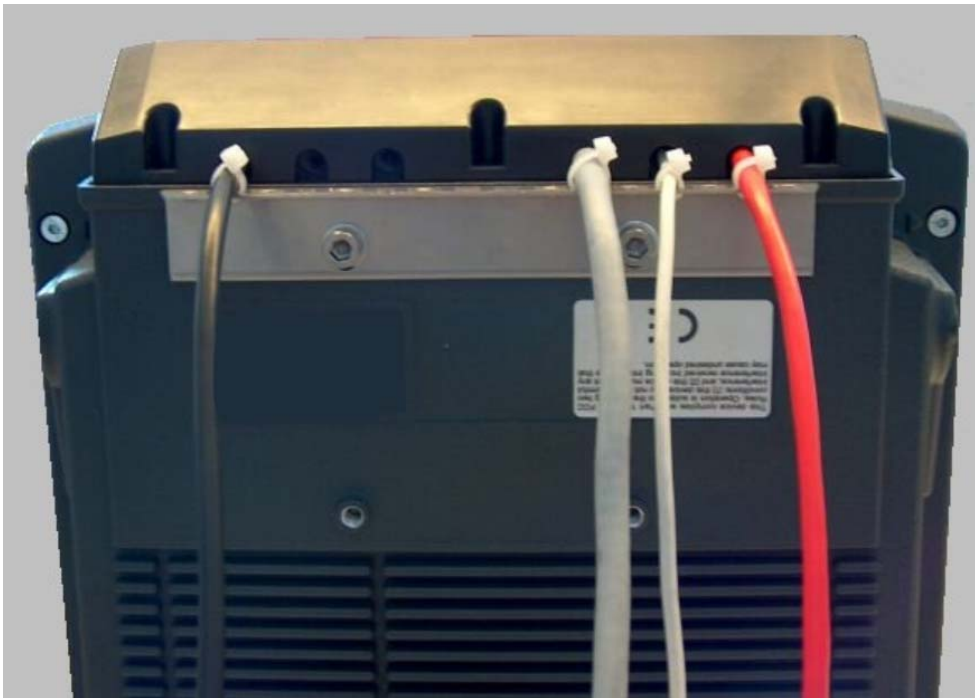


*Figure 3.3: LANpoint XL without a cable cover*

3. Now attach the sealing ends onto the cables.



Take care not to damage the seal of the cable cover! It should be possible to attach the cable cover to the cable duct without using force. The neck collar screws should be screwed firmly, preferably diagonally and always using 5 rotations. The screws need to be retightened after 2 days.



**Figure 3.4:** LANpoint XL with a cable cover

### **3.6. Removing the protective film (display)**

The display of the LANpoint XL is protected during transport by a transparent film.

This film should remain on the display during assembly to avoid damage to the display surface.

Do not remove the film until all assembly steps have been completed.

## 4. Initial operation



Before operating the unit for the first time, carefully read the safety guidelines at the start of this manual.

### 4.1. Powering up the LANpoint XL

Only power up the LANpoint XL after connecting all of the devices.

To power up the LANpoint XL, connect it to an appropriate power supply, and, depending on the version of the device, press either the power button or the ignition signal

Also see *LANpoint XL Operating controls: Front controls (standard)*.



Make sure there is a suitable disconnecting device in the power supply circuit, such as a power button or circuit breaker.

## 4.2. LANpoint XL Operating controls

There are a number of indicator lamps and controls on the front of the LANpoint XL.



The standard model of the LANpoint XL only has four buttons and three indicator lamps on the left-hand side. The figure below displays an extended configuration with 25 buttons (optional).



**Figure 4.1:** LANpoint XL with a 10.4" display and 25 buttons



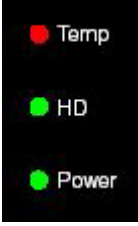
The layout is the same for 10.4" and 12.1" displays.



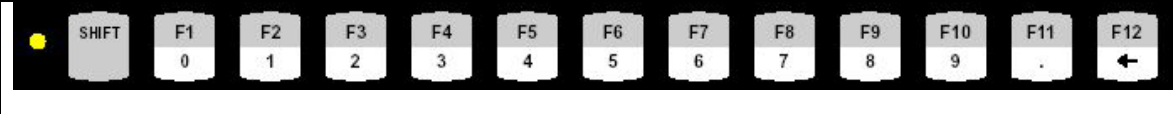
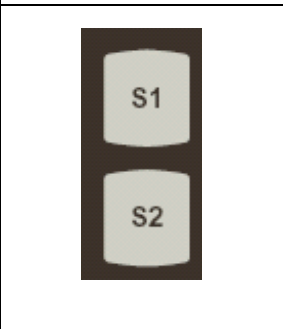
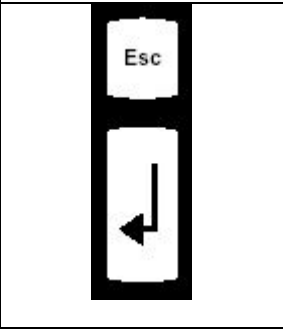
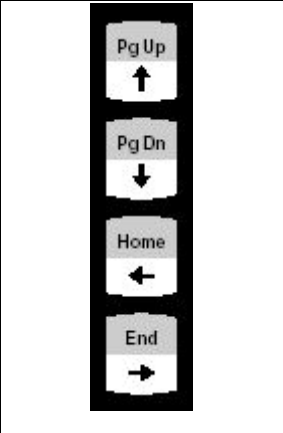
Note for units featuring a **brightness control**:

Even after manually turning off the display lighting, the LANpoint XL will continue to respond to interaction via the keyboard, mouse or touch screen. This means that you can continue to enter commands and data even if the display lighting is off.

### 4.2.1. Front controls (standard)

Indicator/control	Explanation	
	<p><b>ON/OFF:</b> turns the LANpoint XL on or off.</p> <p>This button has been preconfigured by Intelligent Instrumentation to provide the following functions by default:</p>	
	<p>LANpoint XL with a DC power pack and automatic switch-off module</p>	<p>Power button is <b>not</b> used for powering up the unit. If the button is pressed before the shutdown delay time has elapsed, the unit is powered down immediately.</p>
	<p>LANpoint XL with a DC power pack, no automatic switch-off module</p>	<p>Power button is used to power up the unit. If the button is pressed while the unit is operating, this results in a <b>HARD shutdown. This may lead to data loss!</b></p>
	<p>LANpoint XL with an AC power pack and automatic switch-off module</p>	<p>Power button is used to power up the unit. If the button is pressed while the unit is operational, all applications are quit and the LANpoint XL is properly shut down.</p>
	<p>LANpoint XL with an AC power pack, no automatic switch-off module</p>	<p>Power button is used to power up the unit. If the button is pressed while the unit is operating, this results in a <b>HARD shutdown. This may lead to data loss!</b></p>
	<p>+ button for manual brightness control (optional)</p> <p>- button for manual brightness control (optional)</p> <p><b>ON/OFF</b> turns the back light on or off</p>	
	<p><b>Temp</b> (red LED): indicates excessively high or low temperature inside the unit</p> <p><b>HD</b> (green LED): indicates hard drive / Flash drive activity</p> <p><b>Power</b> (green LED): indicates connection to a power supply</p>	

### 4.2.2. Front controls (extended)

Indicator/control	Explanation
	
	<p><b>yellow LED:</b> indicates the status of the SHIFT key</p> <p><b>"0" / F1":</b> digit "0", or function key F1 if the SHIFT key is pressed</p> <p>• • •</p> <p><b>"9" / F10":</b> digit "9", or function key F10 if the SHIFT key is pressed</p> <p><b>". " / F11":</b> decimal point, or function key F11 if the SHIFT key is pressed</p> <p><b>"←" / F12":</b> BACKSPACE, or function key F12 if the SHIFT key is pressed</p>
	<p><b>S1 special keys:</b></p> <p>Pressing S1 has the same effect as simultaneously pressing "CTRL" and "+" on the keypad</p> <p><b>S2 special key:</b></p> <p>Pressing S2 has the same effect as simultaneously pressing "CTRL" and "-" on the keypad</p>
	<p><b>ESC</b> key</p> <p><b>Enter</b> key</p>
	<p><b>↑/PgUp</b> "UP ARROW" or "PAGE UP", depending on the SHIFT key</p> <p><b>↓/PgDn</b> "DOWN ARROW" or "PAGE DOWN", depending on the SHIFT key</p> <p><b>←/Home</b> "LEFT ARROW" or "HOME", depending on the SHIFT key</p> <p><b>→/End</b> "RIGHT ARROW" or "END", depending on the SHIFT key</p>

### 4.3. Operating states

The following operating states are possible for the LANpoint XL:

Status of internal LEDs		LANpoint XL state
Power (green)	Temp (red)	
OFF	OFF	Initial state, idle time (waiting for a new ignition signal after switch-off), no power supply
OFF	FLASHING	Temperature sensor is malfunctioning
OFF	ON	Heating is on (at $T < 0^{\circ}\text{C}$ ), over-temperature warning (at $T > 62^{\circ}\text{C}$ ). The computer will not start until the temperature inside the unit is between 0 and $62^{\circ}\text{C}$ .
ON	OFF	Computer is starting up; normal operational state; shutdown delay time is running
ON	ON	$T < -5^{\circ}\text{C}$ or $T > 70^{\circ}\text{C}$
ON	FLASHING	Temperature sensor is malfunctioning; automatic switch-off message

*Table: Status of power and temp LEDs on the LANpoint XL*

## 5. Maintenance

### 5.1. Cleaning the touch screen



Carefully read the following notes on cleaning the touch screen.

The touch screen's surface should always be kept clean of dirt, dust, finger marks etc. to ensure full visibility of the display. Do not use abrasive cleaning agents, as these may scratch the surface and lead to a deterioration in image quality.

The best results are obtained using a damp, non-abrasive cloth with any commercially available window cleaner that does not contain ammonia. Apply the window cleaner to the cloth instead of spraying it directly onto the touch screen surface.

## 6. BIOS

### 6.1. General

The BIOS in the LANpoint XL tests, initializes and configures the hardware according to the settings. As a last step, the operating system is loaded.

The BIOS used in the LANpoint XL is based on the Phoenix – AwardBIOS v6.00PG.

## 6.2. BIOS boot messages

After the LANpoint XL is switched on, several system messages are displayed on the screen.

### 6.2.1. Startup screen BIOS system check

```
Phoenix - AwardBIOS v6.00PG, An Energy Star Ally
Copyright (C) 1984-2001, Phoenix Technologies, LTD

LP XL BIOS M5S10A01 BIOS 02/18/2004 (c)

Main Processor : VIA C3 400A MHz(100x4.0)
Memory Testing : 245768K 0K +16384K Shard Memory

Primary Master : STI Flash 6.1.0 Rev6.1.0
Primary Slave : None
Secondary Master : None
Secondary Slave : None

Press DEL to enter SETUP
11/25/2002-8606-686B-6A6LLAKDC-00
```

**Figure 6.1:** BIOS system check



The actual screen may vary from the screen displayed here due to a different hardware configuration or a more recent BIOS version.

### 6.2.2. Startup screen BIOS system configuration

```

Phoenix Technologies, LTD
System Configurations

```

CPU Type	: VIA C3	Base Memory	: 640K
CPI ID/ucode ID	: 0673	Extended Memory	: 244736K
CPU Clock	: 400A MHz	Cache Memory	: 64K

Diskette Drive A	: None	Display Type	: EGA/VGA
Diskette Drive B	: None	Serial Port(s)	: 3F8 2F8
Pri. Master Disk	: LBA,PIO 1, 256MB	Parallel Port(s)	: 378
Pri. Slave Disk	: None	SDRAM at Bank	: 0
Sec. Master Disk	: None		
Sec. Slave Disk	: None		

```

USB Storage Device : TEAC FD-05PUW
PCI device listing ...
Bus No. Device No. Func No. Vendor/Device Class Device Class IRQ

```

Bus No.	Device No.	Func No.	Vendor/Device	Class	Device Class	IRQ
0	2	0	10EC 0139	0200	Network Cntrlr	15
0	7	1	1106 0571	0101	IDE Cntrlr	14
0	7	2	1106 3038	0C03	Serial Bus Cntrlr	10
0	7	5	1106 3058	0401	Multimedia Device	11
0	8	0	1180 0475	0607	PCI/CardBus bridge	15
1	0	0	5333 8D01	0300	Display Cntrlr	NA


  

```

Verifying DMI Pool Data .....

```

**Figure 6.2:** Startup screen BIOS system configuration



The actual screen may vary from the screen displayed here due to a different hardware configuration or a more recent BIOS version.

## 6.3. Starting BIOS setup

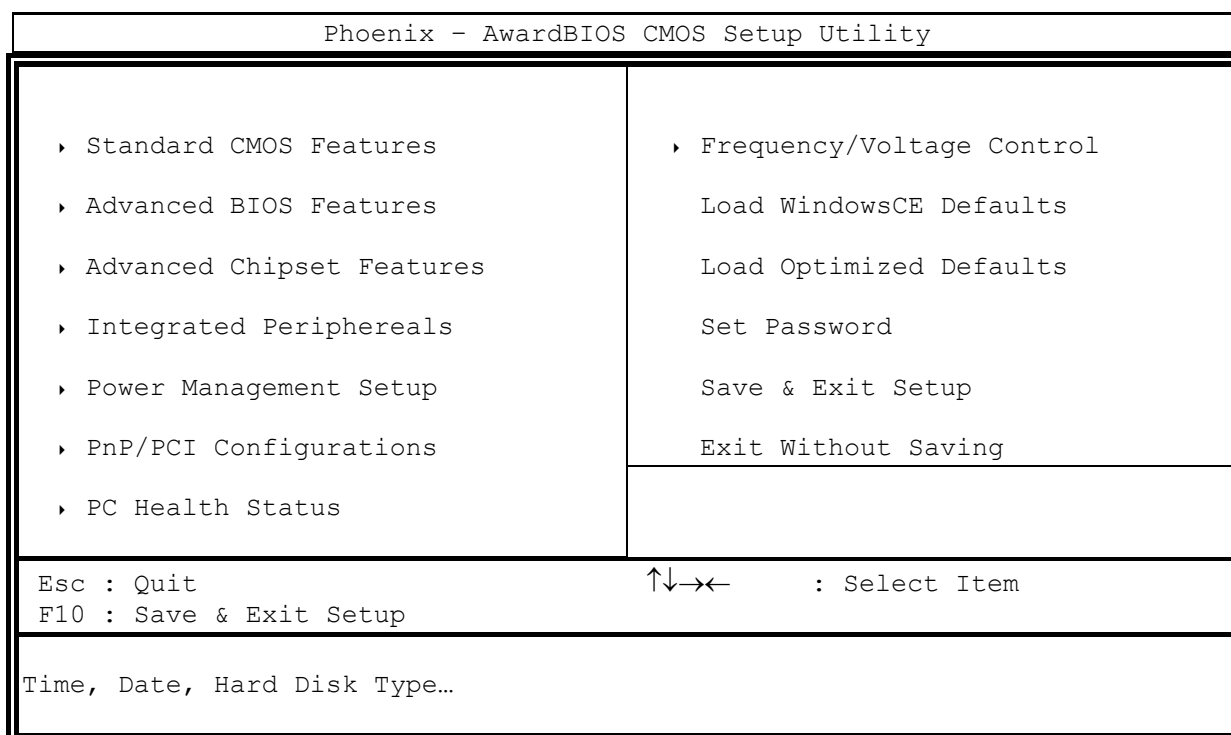
As soon as the BIOS boot screen is displayed, press the “DEL” key to start the setup.



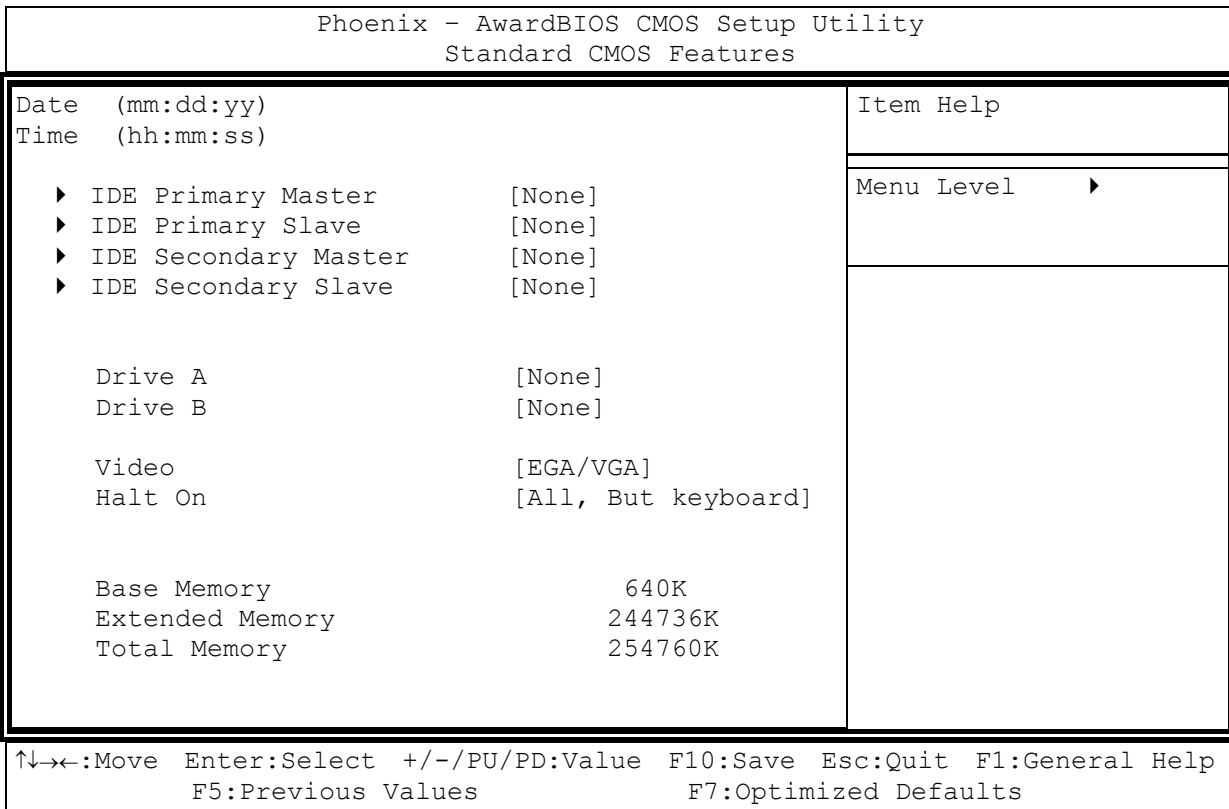
The *Load Optimized Defaults* settings are designed for conflict-free operation of a standard LANpoint XL. Modifications should only be made by persons with detailed OS expertise.

### 6.3.1. Setup pages of the LANpoint XL BIOS

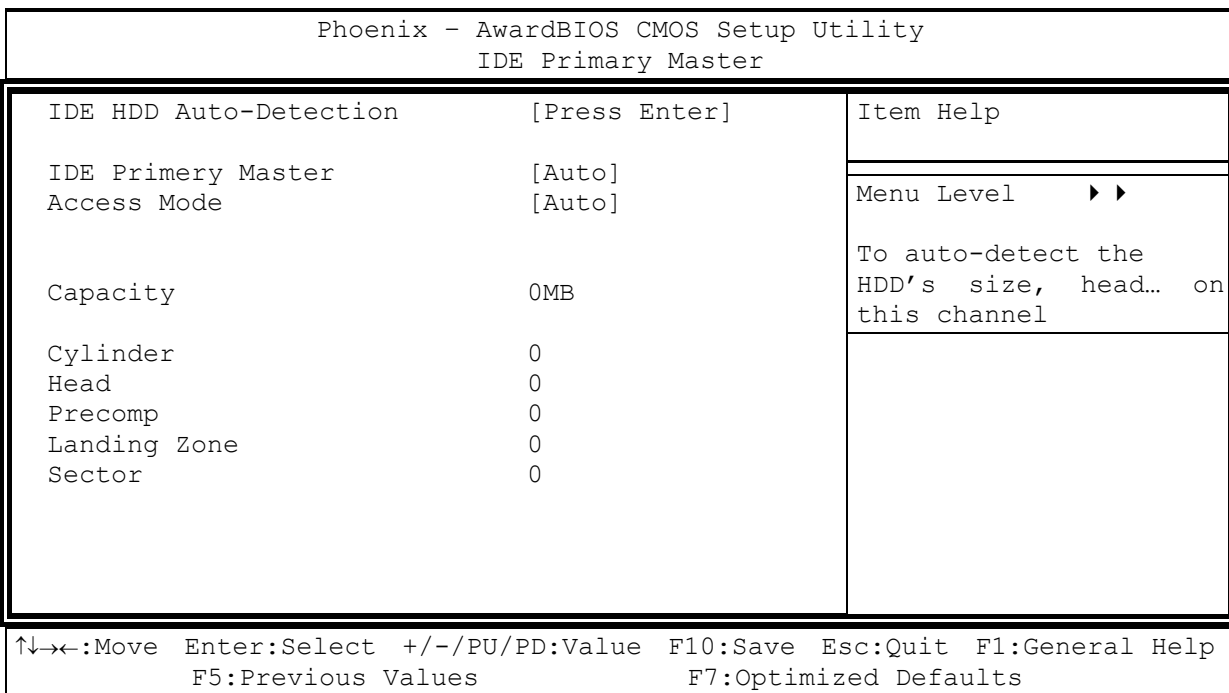
The following section shows the setup pages and default settings of the LANpoint XL BIOS, Version 4472X07G or higher.



**Figure 6.3:** “CMOS SETUP UTILITY” screen



**Figure 6.4: "Standard CMOS Features" screen**



**Figure 6.5: "IDE Primary Master" screen**

Phoenix - AwardBIOS CMOS Setup Utility		
IDE Primary Slave		
IDE HDD Auto-Detection	[Press Enter]	Item Help
IDE Primary Slave	[Auto]	Menu Level ▶▶
Access Mode	[Auto]	To auto-detect the HDD's size, head... on this channel
Access Mode	[Auto]	
Capacity	0MB	
Cylinder	0	
Head	0	
Precomp	0	
Landing Zone	0	
Sector	0	

↑↓←→:Move Enter:Select +/-/PU/PD:Value F10:Save Esc:Quit F1:General Help  
F5:Previous Values F7:Optimized Defaults

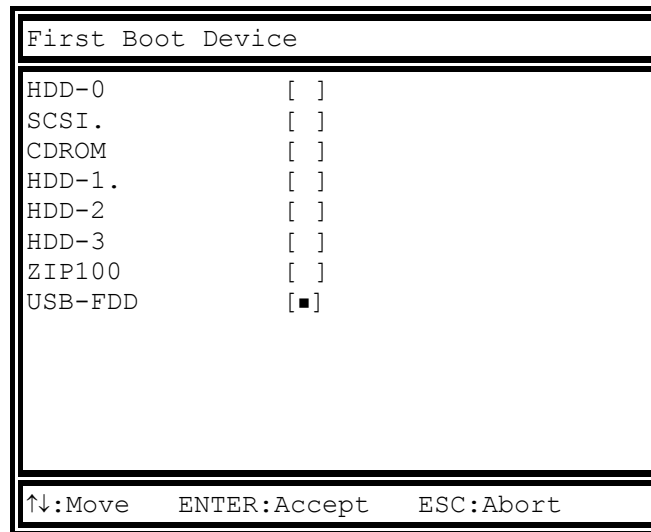
**Figure 6.6: "IDE-Primary Slave" screen**

Video	
EGA/VGA	[■]
CGA 40.	[ ]
CGA 80	[ ]
Mono.	[ ]

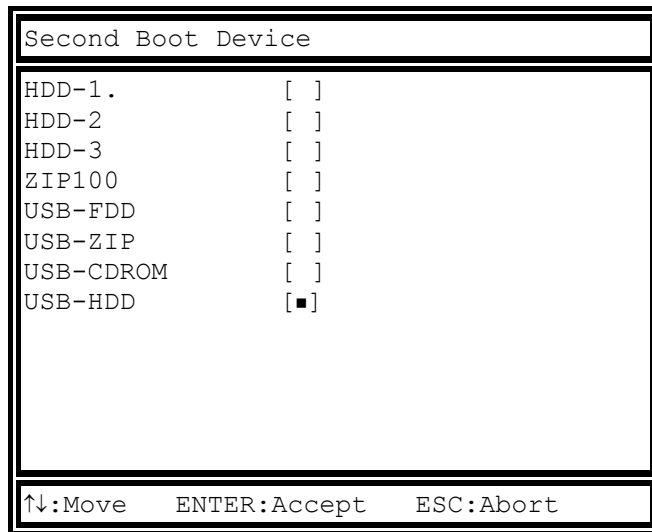
↑↓:Move ENTER:Accept ESC:Abort

**Figure 6.7: "Video" screen**

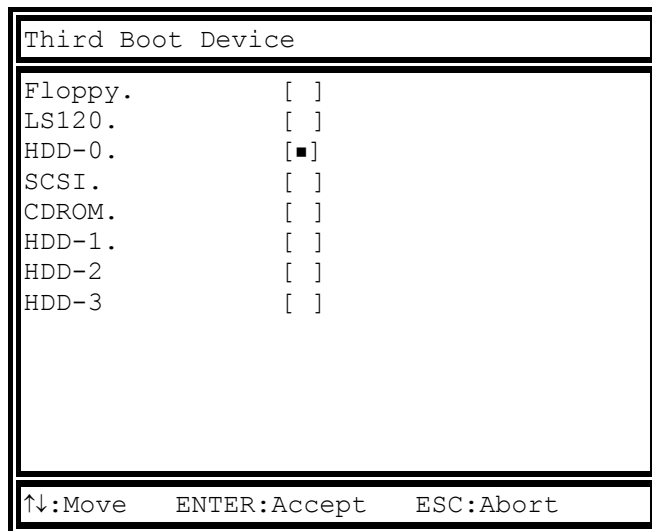




**Figure 6.10:** "First Boot Device" screen



**Figure 6.11::** "Second Boot Device" screen

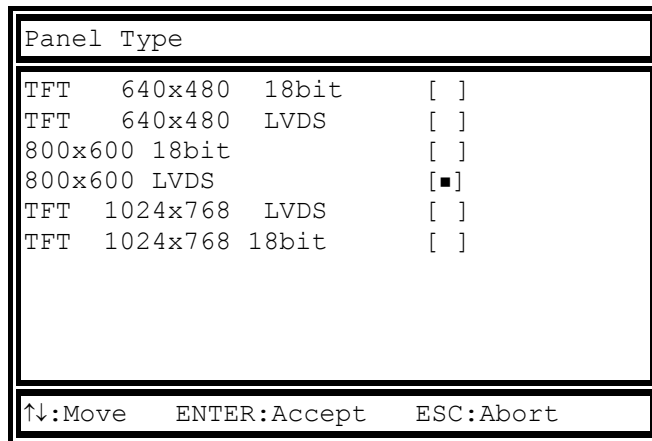


**Figure 6.12:** "Third Boot Device" screen

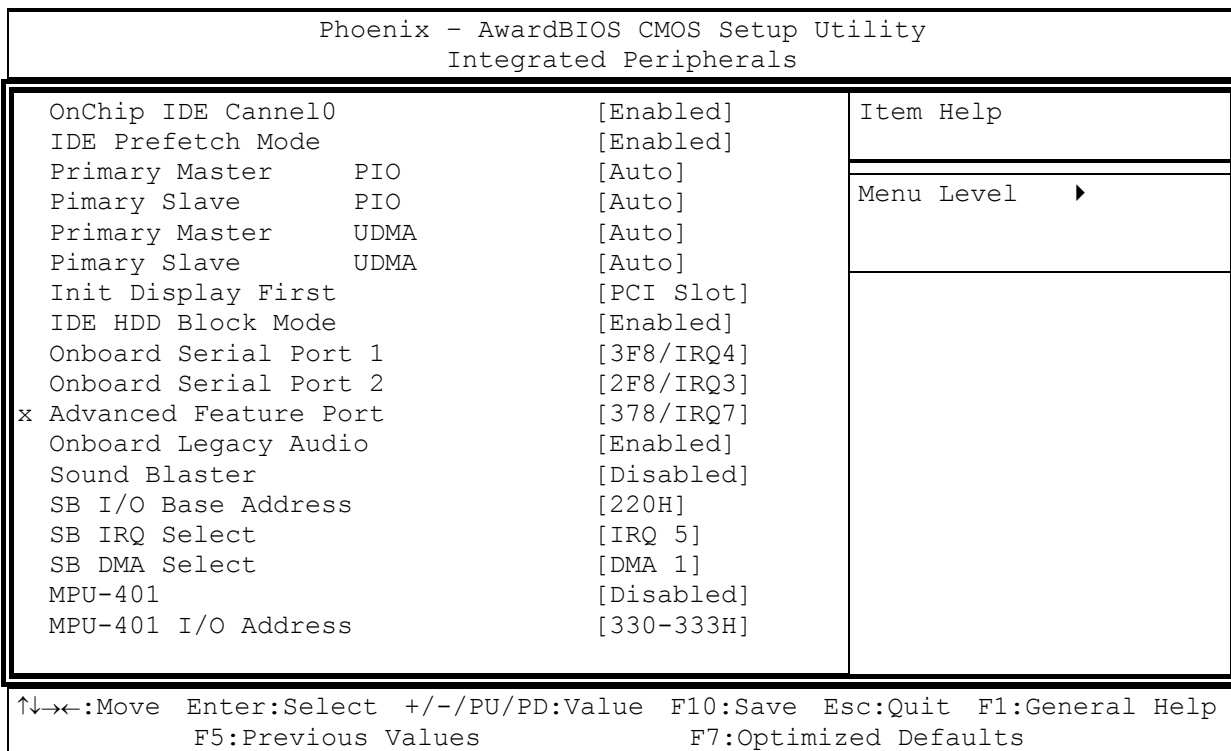
Phoenix - AwardBIOS CMOS Setup Utility		
Advanced Chipset Features		
		Item Help
	DRAM Timing By SPD	[Enabled]
x	SDRAM Cycle Length	3
x	Bank Interleave	[Disabled]
	Memory Hole	[Disabled]
	P2C/C2P Concurrency	[Enabled]
	System BIOS Cacheable	[Enabled]
	Video RAM Cacheable	[Enabled]
	Frame Buffer Size	[16M]
	AGP Aperture Size	[64M]
	AGP-4X Mode	[Enabled]
	AGP Driving Control	[Auto]
x	AGP Driving Value	DA
	Panel Type	[800x600 LVDS]
	Boot Device Select	[Both]
	OnChip USB	[Enabled]
	USB Keyboard Support	[Disabled]
	OnChip Sound	[Auto]
	OnChip Modem	[Auto]
	CPU To PCI Write Buffer	[Enabled]
	PCI Dynamic Bursting	[Enabled]
	PCI Master 0 WS Write	[Enabled]
	PCI Delay Transaction	[Disabled]
	PCI#2 Access #1 Retry	[Enabled]
	AGP Master 1 WS Write	[Enabled]
	AGP Master 1 WS Read	[Disabled]

↑↓←→:Move Enter:Select +/-/PU/PD:Value F10:Save Esc:Quit F1:General Help  
 F5:Previous Values F7:Optimized Defaults

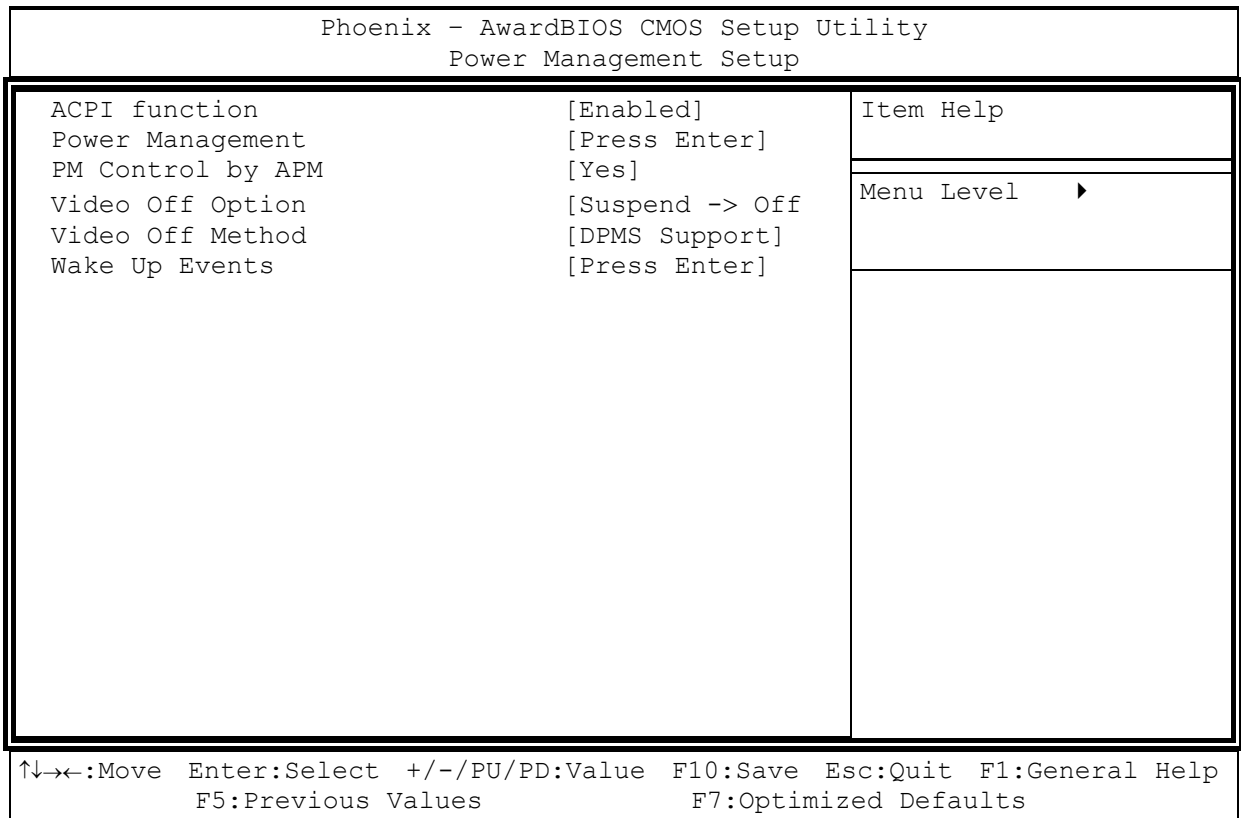
**Figure 6.13:** “Advanced Chipset Features” screen



**Figure 6.14: "Panel Type" screen**



**Figure 6.15: "Integrated Peripherals" screen**



**Figure 6.16:** "Power Management Setup" screen

Phoenix - AwardBIOS CMOS Setup Utility		
PnP/PCI Configurations		
PNP OS Installed	[No]	Item Help
Reset Configuration Data	[Disabled]	
Resources Controlled By	[Auto(ESCD)]	Menu Level ▶
X IRQ Resources	Press Enter	
X DMA Resources	Press Enter	
PCI/VGA Palette Snoop	[Disabled]	
Assign IRQ For VGA	[Enabled]	
Assign IRQ For USB	[Enabled]	

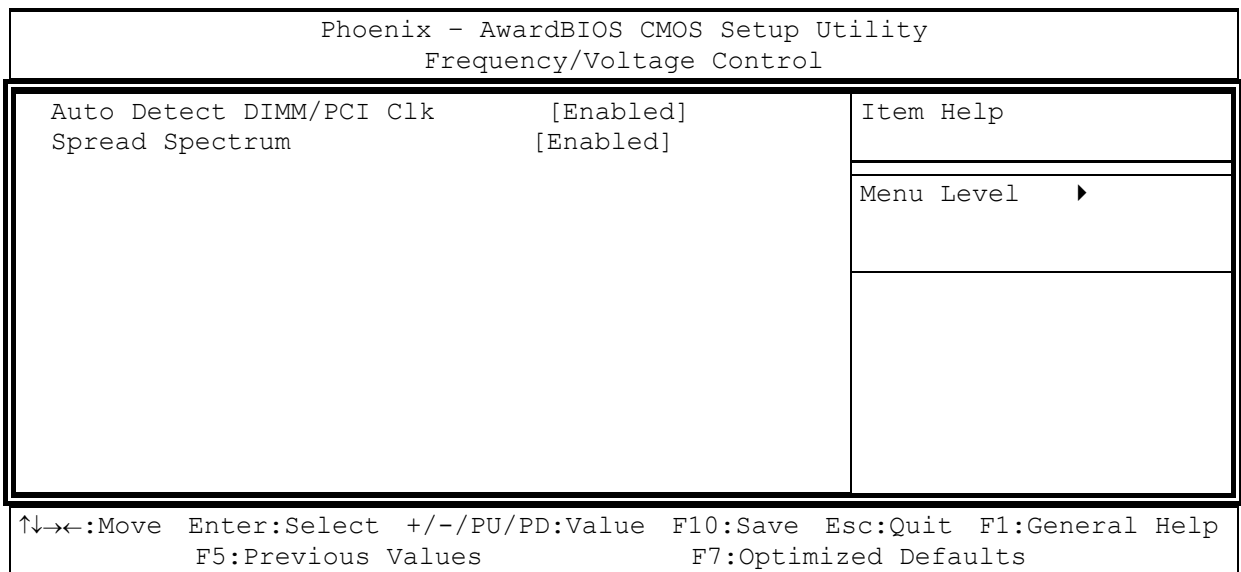
↑↓→←:Move    Enter:Select    +/-/PU/PD:Value    F10:Save    Esc:Quit    F1:General Help  
                   F5:Previous Values                                    F7:Optimized Defaults

**Figure 6.17: "PnP/PCI Configurations" screen**

Phoenix - AwardBIOS CMOS Setup Utility		
PC Health Status		
Current System Temp.	48°C/118°F	Item Help
Current CPUFAN1 Speed	0RPM	
Current CPUFAN2 Speed	0RPM	Menu Level ▶
Vcore	1.08 V	
2.5V	2.57 V	
3.3V	3.30 V	
5V	5.30 V	

↑↓→←:Move    Enter:Select    +/-/PU/PD:Value    F10:Save    Esc:Quit    F1:General Help  
                   F5:Previous Values                                    F7:Optimized Defaults

**Figure 6.18: "PC Health Status" screen**



**Figure 6.19:** "Frequency/ Voltage Control" screen

## 6.4. Power On Self Test (POST)

While the LANpoint XL starts up, a BIOS Power On Self Test (POST) is performed. This initializes and tests the functionality of the processor and the chipset. So-called POST codes are issued by the system during testing.

These codes can be displayed with the help of additional hardware, a PCI POST adapter for the LANpoint XL which displays the I/O port 80 (hexadecimal) on a two-digit seven-segment display. The displayed values provide the user with feedback about the tests. When a system error occurs, for example, the test where the error occurred is specified. POST adapters is particularly useful for troubleshooting because the POST codes can be displayed even if the display adapter has not yet been initialized or the display adapter itself is causing the error.

## 6.5. BIOS hot keys

The hotkeys of the system BIOS of the LANpoint XL provide various functions.

### 6.5.1. Loading the standard settings

#### 6.5.1.1. General information

The system BIOS of the LANpoint XL provides an option for loading default setup settings during a cold start. This may be necessary if, for example, "CRT" is defined in the setup as the boot monitor but no external monitor is connected.

In the default system settings, the boot monitor is defined as "Auto". The ports are checked to see if an external monitor is available, but if the result is negative, the LCD display is used by default.

Generally, the default settings are used to restore the LANpoint XL to an operational state regardless of previous user settings.

#### 6.5.1.2. Loading

Press and hold the "INS" key during start-up until the first screen appears to load the standard settings.

### 6.5.2. Warm start

Press the following key combination:

"CTRL" "ALT" "DEL"

This carries out a "warm" reboot.



In operating systems like Linux or Microsoft Windows, this key combination has a different effect.

## 6.6. BIOS Update

### 6.6.1. General Information

The hardware of the LANpoint XL lets you update the system BIOS without opening the unit.



You should only update the BIOS if the BIOS in your LANpoint XL is severely corrupted.

### 6.6.2. Procedure



During the update operation, the power supply to the unit may not be interrupted. Should this happen, the unit needs to be sent in for repairs.

For every BIOS update, the following procedure should be observed:

#### 1. Programming the new binary file

Proceed as follows:

- Boot into MS-DOS.



When booting into MS-DOS, do not start any network driver or memory management programs such as EMM386 or HIMEM.

- Create a RAM disk.
- Copy **AWDFLASH.EXE** and the current binary file to this RAM disk.
- Start the update with the following command:

```
awdflash 'name of the binary file' /Py /Sn /R
```

The update is carried out without further confirmation and the computer is restarted.

## 2. Configuring the updated BIOS in the **CMOS SETUP UTILITY** menu

After completing step 1, the settings described below need to be configured. Use the arrow buttons “←”, “→”, “↑” and “↓” to navigate and “+” and “-” to change values.

Press “ESC” to abort configuration.

Page	Item	Setting
<b>Main Setup Page</b>	<Load Optimized Defaults> Confirm with “y” (German keyboard: “z”)	No setting possible
<b>PnP/PCI Configurations</b>	<Reset Configuration Data>	Enabled
<b>Main Setup Page</b>	Save with <F10> <Save and Exit>	No setting possible

## 7. LANpoint XL Operation and Configuration

The topics in this section include:

- the Microsoft Windows CE.NET 4.2 operating system
- the initial power-up sequence
- configuring the TCP/IP Parameters
- transferring files from the development computer to the terminal
- creating shared directories to upload and download files to and from the terminal
- Autorun Feature and creating a shortcut on the desktop
- saving the contents in the Windows CE.NET registry
- creating folders on the terminal for permanent storage

### 7.1. The Windows CE.NET 4.2 operating system

On the LANpoint XL runs the Microsoft Windows CE version 4.2 operating system, sometimes called "Windows CE.NET". The operating system configuration includes support for the following hardware devices, among others:

- Ethernet, USB, HD controller
- PC Card devices including: ATA, RF Ethernet, and Compact FLASH. Both 3.3V and 5V PC Cards are supported.
- VIA C3 Eden processor



In LANpoint XL units supplied with a pre-installed Windows CE.NET 4.2 operating system. The Windows CE Operating System is based on a file named NK.BIN, stored on the Compact Flash Card. Do not delete or move the files NK.BIN, BOOTCEPC.PCX, BOOTCEPC, and MACHINE.key.

Without these files, the terminal will not boot.

## 7.2. Initial Power-Up Sequence

The External Power LED on the front of the terminal immediately illuminates when the terminal is powered-up. While the operating system is loading, a status bar moves across the bottom of the boot screen from left to right. When the status bar reaches the right-hand side of the screen, the screen changes to the Windows CE desktop screen.



The installation and configuration of the operating system should only be carried out by professionals familiar with the system environment.

### 7.2.1. Configuring the TCP/IP Parameters

#### WLAN

The assumption is, that LAN (red cross on PCI-RTL81391 icon) is disabled. Go to <Start> – <Settings> - <Network and Dial-up Connections>. Click on Cisco1 icon and choose on File the point “Properties”. Change the IP, DNS and Subnet if you don’t want to use network entry through DHCP. Save your settings with the OK button. Double-click on little monitor icon with a red cross in the taskbar and select <Add new ...>. Set all the wireless options correctly as configured in the Access Point. Click Ok to save the settings, please wait until you can see, that the WLAN connection is established. Look at the little MONITOR icon on the taskbar. (Red cross = not connected, two blue monitor screen = connection established).

**Important save all the Control Panel Settings into the registry with REGFLUSH.EXE !** You will find it on the CFCard Folder.

#### LAN

The assumption is, that WLAN (red cross on CISCO1 icon) is disabled. Go to <Start> – <Settings> - <Network and Dial-up Connections>. Click on PCI-RTL81391 icon and choose on File the point “Properties”. Change the IP, DNS and Subnet if you don’t want to use network entry through DHCP. Click Ok to save the settings, please wait until you can see, that the LAN connection is established. Look at the little NETWORK icon on the taskbar.

**Important save all the Control Panel Settings into the registry with REGFLUSH.EXE !** You will find it on the CFCard Folder.



All changes of Control Panel Settings must be saved in a non-volatile copy of the registry with REGFLUSH.EXE

### 7.2.2. File Transfer Methods

To transfer files from a development computer or any computer to the LANpoint XL terminal, the following methods can be used.

- Use Microsoft ActiveSync 3.8
- Use the Remote File Viewer in the Microsoft eMbedded Tools 4.0 to transfer via ActiveSync
- Use Build/Deploy Solution option in Microsoft Visual Studio.NET 2003
- Use the Remote Manager to upload the application using a Web interface
- Define shared network folders (see section 7.2.3, Accessing Shared Directories).

### 7.2.3. Accessing Shared Directories

Accessing a shared directory on a PC on the Ethernet network allows you to copy files between the terminal and a PC, as well as to update files in the shared directory on the PC, as if that shared directory were stored locally on the terminal.

1. It is a good idea to assign each LANpoint XL terminal a unique name on your network. If this has already been done, skip to step 7.
2. Click on the Start button and select Control Panel.
3. Double-click the System icon to open the System Properties dialog
4. Click on the Device Name tab. Enter a unique identifier in the Device name: field. Enter a description in the Device description: field if you wish.
5. Press the OK button in the System Properties dialog.
6. Run `\CFCard\Regflush` to save the device name settings to non-volatile CF Card memory
7. In the Command Prompt window on the LANpoint XL terminal (Start button, Programs, Command Prompt), enter the command:

```
net use Test \ComputerName\SharedDirectoryName
```

where ComputerName is the computer with which you want to share data. The ComputerName and SharedDirectoryName is defined on the PC beforehand; these values and the methods to set them (and look them up) are operating system dependent. See your system administrator if either or both are unknown to you.

8. A dialog asking for a User name and password may open. Enter the user name and password for the host computer. Some computers may require an entry in the Domain field. Leave this field empty if your computer does not require an entry.
9. Click the OK button.
10. A folder named Test now exists on the terminal under the \Network folder. Below that folder is displayed the contents of the host computer's shared folder.

### 7.2.4. Autorun Feature and Creating a shortcut on the desktop

There is a folder named \Autostart located on the compact flash card (folder \CFCard). Batch files can be placed in this folder for starting programs automatically at reboot. There are three example batch files (START.bat) in folders under the folder \CFCard\BATCH\.

\ICAClient\START.bat will open the CitrixClient;

\RemoteDesktop\START.bat will open the RDP (Remote Desktop Connection).

\InternetExplorer\START.bat opens Microsoft's Internet Explorer.

Copy or create a shortcut of the example file into the folder \autostart\. This file will be executed at the next start of Windows CE.NET. You can view and/or edit the contents of START.bat by using the text editor \Windows\pword.exe. In the File menu, select Open, and change 'Type' to All Documents (\*.\*). Search for the file and press the OK button.

#### Instruction to create a shortcut on the desktop

1. copy for example the file General Information.doc
2. paste it as shortcut in the Autostart directory
3. rename it to GenInfo.lnk
4. open the Start.bat file with Pword.exe as described above
5. add the line: copy \cfcard\autostart\geninfo.lnk \windows\desktop
6. save it and run Start.bat



The file must be named START.bat to work correctly

### 7.2.5. Saving the content in the Windows CE.NET registry

Changes that you make that affect the registry (in dialogs, during some program installations, changes of TCP/IP addresses, and so forth) are held in the Windows CE.NET registry that is in RAM memory. As such, those changes are temporary and will not be in effect when the terminal is rebooted, unlike desktop Windows operating systems.

To make this kind of change permanent, the registry must be stored in (flushed to) non-volatile CFCard memory from which it can be loaded during startup.

## 8. External peripheral devices

This chapter describes the external peripheral devices available for the LANpoint XL.

### 8.1. Keyboard

Any keyboard with a 6-pin mini-DIN plug (PS/2) can be connected to the LANpoint XL.

Resources for the keyboard controller are pre-defined in the system architecture and automatically managed by the BIOS.

All keyboards can be used with all operating systems. No additional drivers are required.

### 8.1.1. SMALL keyboard

A mountable SMALL keyboard (German or English) is available for the LANpoint XL, protection class IP 65.



**Figure 8.1:** SMALL keyboard mounted on the LANpoint XL

SMALL keyboards available from Intelligent Instrumentation:

- Desktop SMALL keyboard, English or German
- Mountable SMALL keyboard, English or German. With the help of a mounting kit, this keyboard can be mounted on a stationary or mobile mounting bracket.

## 8.2. Mouse

Any PS/2-compatible mouse with a standard mini-DIN plug, USB connector or RS-232 plug can be connected to the LANpoint XL. If the mouse has a PS/2 connection, a Y-cable is also required.



It is not possible to use a PS/2 mouse during touch operation.

Only a USB or RS-232 mouse can be used alongside touch operation.

Resources for the PS/2 mouse controller are pre-defined in the system architecture and automatically managed by the BIOS. This is also the case for RS-232 and USB mouse devices.

## 8.3. Serial interfaces

The LANpoint XL features two serial interfaces.

### 8.3.1. Resources

Resources for the serial interfaces are pre-defined in the system architecture and automatically managed by the BIOS. COM1 and COM2 resources can be freely defined via the BIOS. Every interface can be configured for COM1-4.

The standard resources for serial interfaces are:

- COM1: Address 0x3F8 - 0x3FF (hexadecimal), Interrupt IRQ4
- COM2: Address 0x2F8 - 0x2FF (hexadecimal), Interrupt IRQ3
- COM3: Address 0x3E8 - 0x3EF (hexadecimal), Interrupt IRQ4
- COM4: Address 0x2E8 - 0x2EF (hexadecimal), Interrupt IRQ3

### 8.3.2. COM1 options

This section describes what needs to be observed when using the COM1 port to supply power to external equipment.

The resources required for the COM1 controller module are automatically reserved by the BIOS.

#### 8.3.2.1. COM1 as a power supply

The COM1 port can optionally supply externally connected equipment with +12 V or +5 V. The voltages are controlled by internal fuses. Summed with the keyboard and the mouse, the constant current needs to remain below 1.1 A at 5 V. The current consumption at 12 V is also limited to 1.1 A by a fuse. Depending on the specific system configuration, the maximum current consumption at +12 V may be significantly lower.

### 8.3.3. COM2 options

This section describes what needs to be observed when the COM2 options RS-422 and RS-485 are used, and what needs to be observed when they are used to supply power to external devices.

The resources required for the COM2 controller module are automatically reserved by the BIOS.

#### 8.3.3.1. COM2 as electrically-isolated RS-422/485

An electrically-isolated RS-422/485 port is optionally available for the COM2 port of the LANpoint XL. This option provides increased data transfer reliability in environments with a lot of interference and extreme differences in earth potential.



This function requires special adapter cables. These can be ordered from your sales agent.

### 8.3.4. Drivers

#### 8.3.4.1. RS-232 operation

MS-DOS only supports two serial interfaces. Support of COM3 and COM4 is application-specific.

The other operating systems support four serial interfaces.

#### 8.3.4.2. RS-4xx operation

This operating mode is not supported by any of the operating systems available for the LANpoint XL. Applications need to provide their own routines for this mode.

#### 8.3.4.3. Serial interface printers

Any printer with a serial interface can be connected to the LANpoint XL.

### 8.3.5. Serial interface barcode scanners using Wedgece.exe

This utility "wedges" data received thru a COM port into the program with the current focus, as if it were keyed into a keyboard. This is very handy for autoID devices such as serially-connected laser scanners. See the LANpoint XL Utilities and Example Programs Guide for information about configuring the wedgece program.

'wedgece.exe' is the wedge utility program name. The file called 'iiibd.dll' must be in the same folder as wedgece.exe when you launch it.



Make sure that you have configured your scanner for RS-232 and the BAUD rate (as set above) according to the manufacturer's specifications. Otherwise, the software wedge may not function correctly.

### 8.3.6. Tips & tricks

Note that according to the EIA-232-E specification, the maximum cable length is 15 m at 19,200 bps.

By using a correctly terminated twisted-pair cable, however, up to 1,200 m at 100 kbps can be achieved according to the EIA-422-A specification. With a data rate of 1 Mbps and a high-quality cable, it is possible to reach line lengths of up to approximately 400 m.

Errors in RS-232 connections are frequently caused by earth loops. If the two end devices establish an earth connection via RS-232 but do not share the same earth potential in their power supply circuits, then a compensation current may be generated. This is particularly noticeable with long cables.

This compensation current, which is also present at the earthing of the RS-232 connection, may significantly degrade signal quality and effectively stop the data flow. In challenging environments, electrically-isolated connections (via external converters) or differential systems (RS-422/485 port) are strongly recommended.

## 8.4. Plug-in cards

A so-called riser card with a single Bus Master-capable PCI slot is available for the LANpoint XL. This card allows you to upgrade your system with conventional Ultra-Short expansion cards (max. length: 141 mm).



Before adding the module, carefully read the safety instructions at the start of this manual.

Prior to opening the unit, make sure that the operating system has been shut down correctly and that the unit is disconnected from the power supply.

The slot cover on the connector bay needs to be removed and replaced by the expansion card's slot bracket.

The riser card routes the internal PCI bus signals (P22 of the motherboard) to a standard plug-in slot.

### 8.4.1. Resources

The riser card itself does not require any system resources. You need to be familiar with the plug-in card's resource requirements to avoid conflicts with standard system resources.

Even in worst-case operating scenarios, the power consumption of all added plug-in cards must not exceed 20 W (also see *Appendix A / System equipment / Power supply*).



Make sure to also accommodate the power requirements of external peripheral equipment (keyboard, mouse, scanner etc.)!

### 8.4.2. Installation

The plug-in card is fastened to the slot bay at the back of the unit by its slot bracket.

### **8.4.3. Riser card with 1x PCI**

This riser card provides a Master-capable PCI slot (PCI Rev 2.1).

With 2.5" hard drives, component heights of up to 12 mm are possible. Otherwise, refer to the PCI specifications for maximum component heights. The maximum length of the plug-in card is 141 mm.

### **8.4.4. Drivers**

The riser card is fully transparent for all operating systems, i.e. no drivers are required.

Some plug-in cards which are inserted into riser cards may require additional drivers. These drivers need to be supplied by the respective card manufacturers.

## 8.5. Automatic switch-off and heating

LANpoint XL models with DC voltage can optionally be equipped with either an automatic switch-off module or an automatic switch-off and heating module.

If the heating option is implemented, the LANpoint XL can be operated at temperatures ranging from maximally  $-30^{\circ}\text{C}$  to  $+50^{\circ}\text{C}$  (see chapter 11, *Technical Data / Environmental conditions*).

### 8.5.1. Modes of operation

If wired up accordingly, the LANpoint XL conveniently switches off together with the vehicle's ignition. As a sudden power cut-off can lead to data loss in some operating systems (for example, Windows NT 4.0), the system needs to be shut down in a regular fashion (hardware and software-implemented) when the ignition is switched off.

The LANpoint XL is connected to the vehicle with three supply lines. *DC+* and *DC-* are linked directly to the vehicle's power supply. Make sure the lines are connected directly to the battery and not to high-interference supply lines (for example, motor supply) or to supply lines already taxed by other consumers. The supply voltage connected is then linked to the LANpoint XL's *Ignition* input via a switch, for example, the key switch of the ignition.

Heating is required if you want to operate the LANpoint XL at environmental temperatures below  $0^{\circ}\text{C}$ .

In the following two sections, the main functions of the automatic heating and switch-off modules are described. For detailed information on the automatic switch-off and heating modules – complete with pre-defined thresholds – refer to the program flowchart diagrams (part 1 and 2) below.

### 8.5.2. Resources

The automatic switch-off/heating module is configured using the COM2 port (which is not pre-assigned during normal operation).



The COM2 port is only reserved while the system controller that controls the automatic switch-off and heating module is being configured. No external device may be connected to the COM2 port while this is happening.

Once configuration is finished, COM2 is again available for other devices.

### 8.5.3. Automatic switch-off

When the ignition is switched on, the LANpoint XL is supplied with voltage and begins checking its internal temperature and automatic switch-off function. Once the environmental conditions have been verified as acceptable, the LANpoint XL starts the operating system proper.

During the first three minutes of the start-up phase, none of the surrounding conditions, such as the internal temperature or the *Ignition* input status, are checked. This allows the operating system and the operating software for the automatic switch-off module to fully load without interruption.

Following this three-minute period, the internal temperature of the unit and the status of the *Ignition* input are checked continuously.

If the inner temperature of the LANpoint XL reaches a critical range, the operating system is shut down regularly and the computer remains switched off until the temperature is back in the permitted range.

If the *Ignition* input is switched to earth potential or a potential-free source during normal operation, the unit switches to shutdown delay time. In this state, the device continues to operate normally until the delay time (for example, 15 minutes) has elapsed.

- If the ignition is triggered again during this time, the LANpoint XL resumes normal operation.
- If, however, the delay time elapses, the operating system is regularly shut down by the operating software and the unit is automatically switched off (for example, after three minutes, or after a signal from the operating software).

### 8.5.4. Program flowchart for automatic switch-off / automatic switch-off & automatic heating

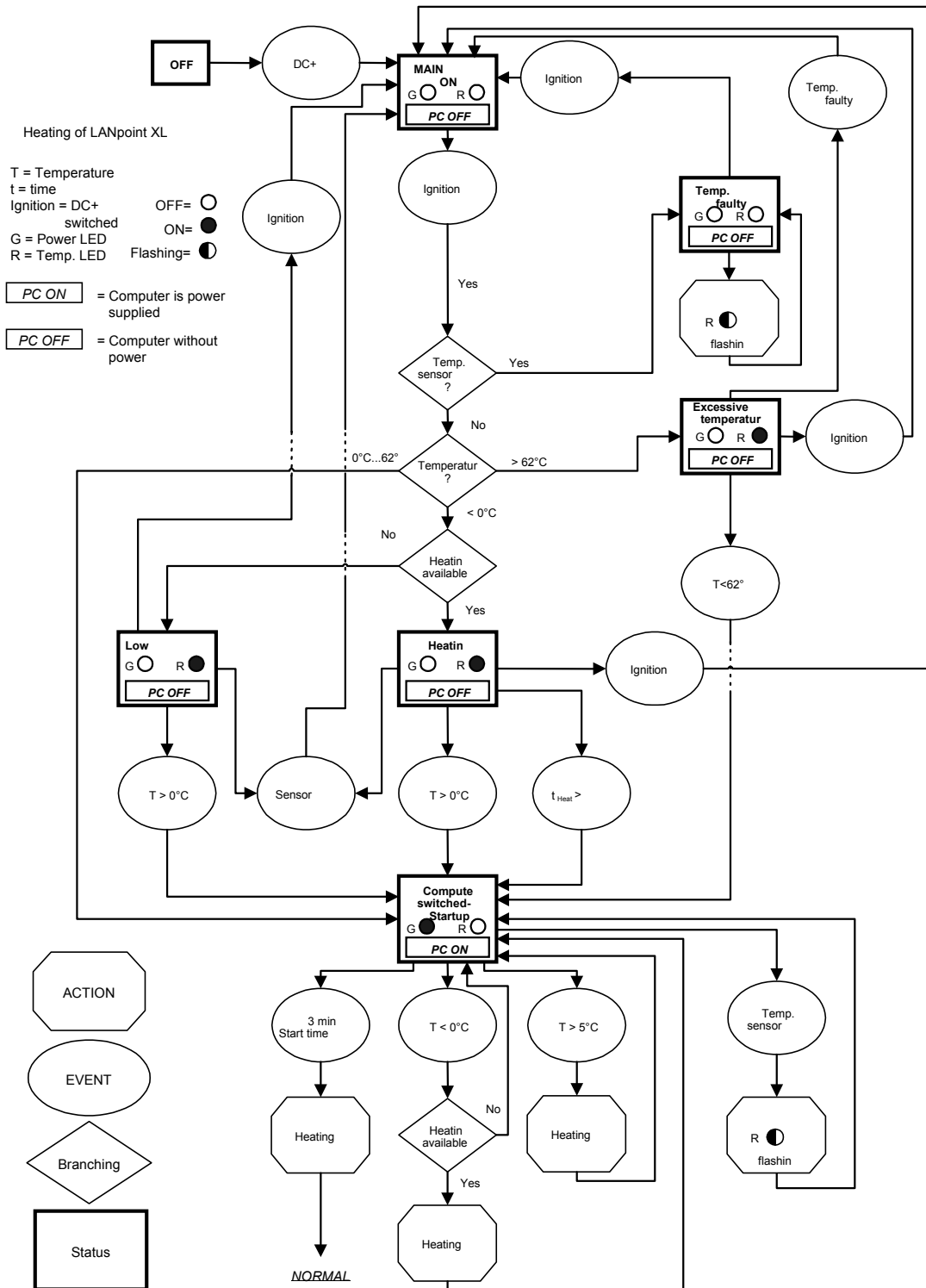


Figure 9.1: Program flowchart part 1

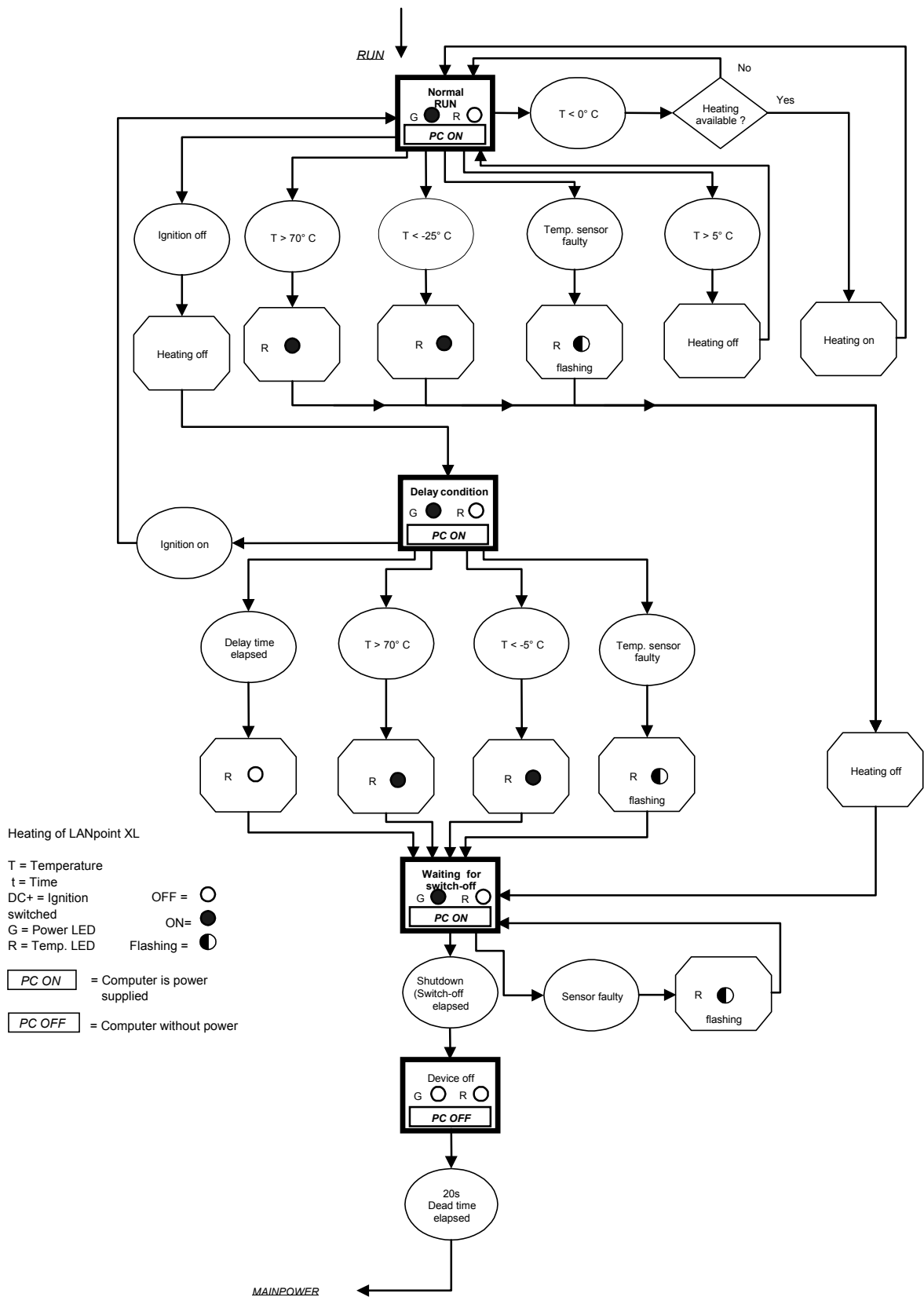


Figure 9.2: Program flowchart part 2

## 8.6. MPCCOM (DOS only)



The program MPCCOM has been developed for use in DOS. It does **not** run in **Windows CE.NET 4.2**.

The program MPCCOM, which is started from DOS, lets you configure parameters for the following functions:

- Display the current version of your environment controller software as well as statistical, configuration and control functions (temperature, ignition and so on)
- Change the switch-off (switch-off ) and switch-off delay time
- Change the reaction time of the power button on the unit's front panel
- Set how the front panel power button is to be interpreted
- Set whether the LANpoint XL is to constantly control the ignition signal during operation

### Operation

Calling `MPCCOM.EXE -h` generates the following messages:

```
MPCCOM -d time0      ...set power-key time
                    (time0=time to wait before keypress is
                    recognized in 100ms
                    (valid values [1..255])

MPCCOM -h           ...show this help
MPCCOM -info, -i    ...readout a lot of info stored in EEPROM
MPCCOM -p value     ...set power-key mode
                    (0=power-key completely disabled
                    1=wait for the power-key to startup & use the
                    power-key to switch off the device
                    2=ignore the power-key at startup & use the
                    power-key to switch off the device
                    3=wait for the power-key to startup & ignore the
                    power-key on the working device

MPCCOM -t time1 time2 ...set timer values in sec (valid values [1..65535])
                    (time1 = delay time, time2 = switchoff time)

MPCCOM -x value     ...set ignition monitoring when device ist working
                    (0=use ignition for automatic switch-off
                    1=ignore ignition if device is working)
```

Statistics, for example, are generated by calling `MPCCOM.EXE -i`:

```

PIC-Version: 1.4                               MPCCOM-Version:      :      1.4
Last Update: 05.11.2003
Working hour backlight : 88h 30min or 3d, 16h and 30min
Working hour device   : 93h 50min or 3d, 21h and 50min
Delay time            :      900s           Switchoff time      :      180s
Brightness value      :      0             Switchoff automatic  :      yes
Brightness control    :      yes           Heating automatic    :      yes
Backlight key off     :      no            "+" & "-" keys off  :      no
Power key off         :      no            Shift key off        :      no
Shift key is CAPS_lock :      yes          Shift key state saved :      no
Act. brightness saved :      no            Use switchoff auto   :      yes
Wait for powerkey     :      no            Wait for ignition    :      yes
Switch-on device count :      67           Powerkey-time        :      2.0s
Switch backlight-volt :      393           Switch-on/off bkl-sw :      7
Powerkey sw-on count  :      0             Powerkey sw-off count :      5
Ignition sw-on count  :      67           Switch-off auto count :      1
PS-ON switch-off count :      14          Temp-sensor error count:      0
Overtemp sw-off count :      0             Lowtemp sw-off count :      0
Heating active startup :      0            Heating active working :      2
Startup temp -> min    :      19°C          Startup temp -> max   :      47°C
Working temp -> min    :      19°C          Working temp -> max   :      52°C
Actual shutdown reason :      unknown
Last shutdown reason  :      unknown

```

## 9. Appendix A: Technical specifications

### 9.1. System equipment

<b>9.1.1. Mechanical</b>	
<b>Housing</b>	<ul style="list-style-type: none"> <li>• Rugged aluminium cast housing with integrated heat sink</li> <li>• Hardly combustible (acc. to UL94V-0)</li> <li>• Protection class IP54 (upgradeable to IP65)</li> <li>• ESD protected</li> <li>• Weight of the LANpoint XL with a 10.4" front panel: approx. 5.0 kg (depending on configuration)</li> </ul>
<b>Display panel</b>	<ul style="list-style-type: none"> <li>• 10.4" SVGA, 230cd/m<sup>2</sup>, optional 4-wire touch controller, with brightness regulation</li> <li>• 10.4" SVGA, 400cd/m<sup>2</sup>, optional 4-wire touch controller, with brightness regulation</li> <li>• 12.1" SVGA, 300cd/m<sup>2</sup>, optional 8-wire touch controller, with brightness regulation</li> <li>• 12,1" XGA, 400cd/m<sup>2</sup>, optional 8-wire touch controller, with brightness regulation</li> </ul>
<b>Back of unit, bottom side</b>	<ul style="list-style-type: none"> <li>• Cable cover (splash guard)</li> <li>• Optional antenna fitting for wireless LAN</li> </ul>

<b>9.1.2. Motherboard</b>	
<b>CPU</b>	<ul style="list-style-type: none"> <li>• VIA C3 Eden 400MHz</li> <li>• VIA C3 Eden 733MHz</li> </ul>
<b>Chipset</b>	<ul style="list-style-type: none"> <li>• VIA 8606T Northbridge</li> <li>• VIA VT82C686B Southbridge</li> </ul>
<b>Bus Interface</b>	<ul style="list-style-type: none"> <li>• PCI bus (PCI 2.1)</li> </ul>
<b>Cache</b>	<ul style="list-style-type: none"> <li>• 128 kB Level 1 Cache: CPU-internal</li> <li>• 64 kB Level 2 Cache: CPU-internal</li> </ul>
<b>RAM</b>	<ul style="list-style-type: none"> <li>• 64 – 512 MB in one SO-SIMM slot</li> <li>• Fully cacheable</li> <li>• SDRAM technology</li> </ul>
<b>BIOS</b>	<ul style="list-style-type: none"> <li>• Phoenix/AWARD Inc. BIOS 6.0 BIOS with APM, PnP</li> <li>• Programmable in the system</li> <li>• BIOS POST self test</li> </ul>
<b>Slots for standard plug-in cards</b>	<ul style="list-style-type: none"> <li>• A riser card is available for extensions:</li> <li>• 1 x PCI slot 32 bit, 5 V</li> </ul>
<b>Real-time clock</b>	<ul style="list-style-type: none"> <li>• Real-time clock with 10 years power reserve</li> </ul>
<b>IDE interface</b>	<ul style="list-style-type: none"> <li>• Supports up to two IDE devices from PIO-Mode 3/4 to UDMA/33. Connection via a 44-pin connector (2 mm grid). Connectable devices:</li> <li>• 2.5" hard drives (enquire about the capacities currently available)</li> <li>• 2.5" Flash drives (IDE) (enquire about the capacities currently available)</li> <li>• CompactFlash type I/II</li> </ul>
<b>Floppy disk drive</b>	<ul style="list-style-type: none"> <li>• Supports an external USB floppy disk drive 3.5"</li> <li>• ESD level 4 protected (acc. to EN 61000-4-2)</li> </ul>
<b>Fan</b>	<ul style="list-style-type: none"> <li>• optional</li> </ul>

<b>Serial interfaces</b>	<ul style="list-style-type: none"><li>• 1st serial port:</li><li>• 115,200 Baud max (16550A compatible, 16 bytes FIFO)</li><li>• ESD level 4 protected (acc. to EN 61000-4-2)</li><li>• 2nd serial port:</li><li>• 115,200 Baud max (16550A compatible, 16 bytes FIFO)</li><li>• Supports RS-232 on an external 9-pin D-Sub connection</li><li>• ESD level 4 protected (acc. to EN 61000-4-2)</li></ul>
<b>Keyboard/mouse connection</b>	<ul style="list-style-type: none"><li>• Keyboard/mouse: 6-pin Mini-DIN connector, combination connector, Y-cable for PS/2 keyboard and mouse required</li><li>• Internally-protected power supply for keyboard and mouse</li><li>• ESD level 3 protected (acc. to EN 61000-4-2)</li></ul>
<b>USB-connection</b>	<ul style="list-style-type: none"><li>• 2 x stacked USB connector (USB 1.1) with 0.5 A reserved for each port</li><li>• ESD level 3 protected (acc. to EN 61000-4-2)</li></ul>
<b>Software compatibility</b>	<ul style="list-style-type: none"><li>• MS-DOS 6.x</li><li>• Windows NT 4.0, Windows NT Embedded, Windows 2000, Windows XP Embedded</li><li>• Linux</li></ul>

<b>9.1.3. LCD / CRT interface</b>	
<b>VGA controller</b>	<ul style="list-style-type: none"> <li>• Integrated Savage4 2D/3D/Video booster</li> <li>• Shared memory architecture</li> <li>• Resolution up to 1280 x 1024</li> <li>• Up to 32 bit colour depth (depending on LCD used)</li> <li>• Simultaneous LCD / CRT operation</li> <li>• Various LCDs are supported (up to 8 LCD displays can be defined in the VGA BIOS)</li> <li>• Drivers available for Windows NT 4.0/Embedded und Windows 2000, Windows XP Embedded and Linux</li> </ul>
<b>9.1.4. Touch interface (optional)</b>	
<b>Analog touch controller</b>	<ul style="list-style-type: none"> <li>• 12bit touch controller for 4-/5-/8-wire touch screens</li> <li>• Drivers available for MS-DOS 6.2x, Windows NT4.0/Embedded, Windows 2000, WindowsXP Embedded and Linux</li> </ul>
<b>Analog touch screens</b>	<ul style="list-style-type: none"> <li>• Available for:</li> <li>• 10.4" and 12.1" LCD displays</li> <li>• Others on request</li> </ul>
<b>Analog touch connection</b>	<ul style="list-style-type: none"> <li>• Internal plug-in connector</li> <li>• Interface is ESD level 4 protected (acc. to EN 61000-4-2)</li> </ul>

<b>9.1.5. Network interface</b>	
<b>Network controller</b>	<ul style="list-style-type: none"> <li>• Realtek RTL8139 controller 10/100 MB/s</li> <li>• Drivers available for MS-DOS 6.2x, Windows 98, Windows NT4.0/Embedded, Windows 2000, Windows XP Embedded, Windows CE.NET 4.2, and Linux</li> </ul>
<b>Network connection</b>	<ul style="list-style-type: none"> <li>• RJ45 plug-in connector</li> <li>• Integrated transmitter</li> <li>• Two integrated status LEDs</li> </ul>
<b>9.1.6. ADC/MDC interface (optional)</b>	
<b>Properties</b>	<ul style="list-style-type: none"> <li>• Four electrically-isolated outputs</li> <li>• 16 electrically-isolated inputs</li> <li>• PCI bus</li> <li>• Drivers available for Windows NT 4.0, Windows 2000 and Windows XP</li> <li>• Drivers for Windows 98/ME or CE.NET on request</li> </ul>
<b>ADC/MDC connection</b>	<ul style="list-style-type: none"> <li>• One 37-pin D-Sub plug-in connector</li> </ul>
<b>9.1.7. Cardbus interface</b>	
<b>Cardbus controller</b>	<ul style="list-style-type: none"> <li>• Ricoh R5C475II</li> <li>• PCI Rev. 2.2</li> <li>• Driver support in Windows 2000, Windows XP, CE.NET, and Linux (operating system support only, plug-in connector drivers to be supplied by the plug-in card manufacturer)</li> </ul>
<b>Cardbus slot</b>	<ul style="list-style-type: none"> <li>• 1 x type 1 or 1 x type 2</li> <li>• Accessible at the back of the unit</li> </ul>

<b>9.1.8. Power supply (The device model is displayed on the device type plate)</b>	
<b>AC power supply internal</b>	<ul style="list-style-type: none"> <li>• 115 V / 230 V, 50-60 Hz</li> <li>• Max. output: 100 W</li> <li>• Withstands bursts up to 4 kV</li> <li>• Electrically-isolated</li> <li>• Automatic switch-off module (optional), supports Windows NT 4.0, Windows 2000, Windows XP, Windows CE.NET, and Linux</li> <li>• Withstands bursts up to 4 kV Type: AC-1</li> <li>• Nominal current 1 A</li> </ul>
<b>DC power supply 24/48 VDC 60 W internal type: DC-2</b>	<ul style="list-style-type: none"> <li>• 24/48 VDC nominal (down to 11 V for 20 s max.)</li> <li>• Voltage range: 18-59 VDC</li> <li>• Covers power outages up to 5 ms</li> <li>• Electrically-isolated</li> <li>• Max. output: 60 W</li> <li>• Automatic switch-off module (optional), supports Windows NT 4.0, Windows 2000, Windows XP, Windows CE.NET, and Linux</li> <li>• Display heating (optional)</li> <li>• Withstands bursts up to 2 kV</li> <li>• Nominal current 3.7 A</li> <li>• Connection only to SELV circuit<sup>2)</sup></li> </ul>
<b>DC power supply 24/48 VDC 100 W internal type: DC-3</b>	<ul style="list-style-type: none"> <li>• 24/48 VDC nominal (down to 11 V for 20 s max.)</li> <li>• Voltage range: 18-59 VDC</li> <li>• Covers power outages up to 5 ms</li> <li>• Electrically-isolated</li> <li>• Max. output: 100 W</li> <li>• Automatic switch-off module (optional), supports Windows NT 4.0, Windows 2000, Windows XP, Windows CE.NET, and Linux</li> <li>• Display heating (optional)</li> <li>• Withstands bursts up to 2 kV</li> <li>• Nominal current 6.2 A</li> <li>• Connection only to SELV circuit<sup>2)</sup></li> </ul>
<b>DC power supply 12 VDC 100 W internal type: DC-1</b>	<ul style="list-style-type: none"> <li>• 12 VDC nominal (down to 6 V for 20 s max.)</li> <li>• Voltage range: 9-16 VDC</li> <li>• Covers power outages up to 5 ms</li> <li>• Electrically-isolated</li> <li>• Max. output: 100 W (at 9-16 VDC), 80 W (at 6-9 VDC)</li> <li>• Automatic switch-off module (optional), supports Windows NT 4.0, Windows 2000, Windows XP, Windows CE.NET and Linux</li> <li>• Display heating (optional)</li> </ul>

	<ul style="list-style-type: none"> <li>• Withstands bursts up to 2 kV</li> <li>• Nominal current 15 A</li> <li>• Connection only to SELV circuit<sup>2)</sup></li> </ul>
<b>Power consumption</b>	<ul style="list-style-type: none"> <li>• Average 30 W (LANpoint XL/110 SVGA with CompactFlash)</li> <li>• Max. 100 W (LANpoint XL/110 VGA with CompactFlash ) in heating mode</li> <li>• Standby 1 W (LANpoint XL/110 SVGA with DC power supply in standby mode)</li> </ul>

<sup>2)</sup> The SELV circuit is a secondary circuit that is designed and protected that its voltages do not exceed a safe value during normal and single fault conditions.

<b>9.1.9. Maximal power available for peripheral devices</b>			
Power supply	Motherboard	with no internal fan	with internal fan
DC-1	400 MHz motherboard	24 W	28 W
DC-1	733 MHz motherboard	16 W	20 W
DC-3	400 MHz motherboard	13.2 W	26.2 W
DC-3	733 MHz motherboard	5 W	18 W
AC-1	400 MHz motherboard	13.2 W	26.2 W
AC-1	733 MHz motherboard	5 W	18 W

<b>9.1.10. Power supply fuses</b>		
<b>Power supply</b>	<b>Fuse type</b>	<b>Examples</b>
DC-1, DC-5	5x20 mm T 16 A L / 250 V	<ul style="list-style-type: none"> <li>• Wickmann 195-2160 16 A / 250 V</li> <li>• Siba 179120 (SIBA Nr. 7000135) 16 A / 250 V</li> <li>• or similar devices produced by other manufacturers</li> </ul>
DC-2	5x20 mm T 6,3 A H / 250 V	<ul style="list-style-type: none"> <li>• Bussman S505-6.3 A</li> <li>• Wickmann 181-6.3 A</li> <li>• Littelfuse 215 06.3</li> <li>• Schurter 0001.2512</li> <li>• Siba 70 007 65 6,3 A</li> <li>• Elu 179200 6,3 A</li> <li>• or similar devices produced by other manufacturers</li> </ul>
DC-3, DC-4	5x20 mm T 12,5 A L / 250 V	<ul style="list-style-type: none"> <li>• Wickmann 195-2125 12,5 A / 250 V</li> <li>• Siba 179120 (SIBA Nr. 7000135) 12,5 A / 250V</li> <li>• or similar devices produced by other manufacturers</li> </ul>
AC-1	5x20 mm T 1,25 A H / 250 V	<ul style="list-style-type: none"> <li>• Wickmann 181-1.25 A</li> <li>• or similar devices produced by other manufacturers</li> </ul>

<b>9.1.11. Environmental conditions</b>											
<b>Operating temperature</b>	<ul style="list-style-type: none"> <li>In accordance with EN 60068-2-1/2</li> <li>The permissible ambient temperature is:</li> </ul> <table border="1"> <thead> <tr> <th>Operating temperature [°C]</th> <th>Operating temperature with heating [°C]</th> </tr> </thead> <tbody> <tr> <td>0 to +50</td> <td>-30 to +50</td> </tr> </tbody> </table>	Operating temperature [°C]	Operating temperature with heating [°C]	0 to +50	-30 to +50						
Operating temperature [°C]	Operating temperature with heating [°C]										
0 to +50	-30 to +50										
<b>Storage temperature</b>	<ul style="list-style-type: none"> <li>In accordance with EN 60068-2-1/2</li> <li>The permissible ambient temperature depends on the display used .</li> </ul> <table border="1"> <thead> <tr> <th>Display</th> <th>Storage temperature<sup>3)</sup> [°C]</th> </tr> </thead> <tbody> <tr> <td>10.4" VGA</td> <td>-35 to +65</td> </tr> <tr> <td>10.4" SVGA</td> <td>-20 to +60</td> </tr> <tr> <td>12.1" SVGA</td> <td>-25 to +60</td> </tr> <tr> <td>12.1" XGA</td> <td>-20 to +65</td> </tr> </tbody> </table>	Display	Storage temperature <sup>3)</sup> [°C]	10.4" VGA	-35 to +65	10.4" SVGA	-20 to +60	12.1" SVGA	-25 to +60	12.1" XGA	-20 to +65
Display	Storage temperature <sup>3)</sup> [°C]										
10.4" VGA	-35 to +65										
10.4" SVGA	-20 to +60										
12.1" SVGA	-25 to +60										
12.1" XGA	-20 to +65										
<b>Relative humidity</b>	<ul style="list-style-type: none"> <li>5% to 95% at 40° C, non-condensating</li> <li>(in accordance with EN 60068-2-3)</li> </ul>										
<b>Vibration</b>	<ul style="list-style-type: none"> <li>Class 7M3 (acc. to EN 60721-3), test acceleration: 5 g effective 10-2000 Hz, during operation, with Flash drive</li> </ul>										
<b>Shock</b>	<ul style="list-style-type: none"> <li>Class 7M3 (acc. to EN 60721-3), test acceleration: half sine of 30 g peak, during operation, with Flash drive</li> </ul>										

<sup>3)</sup> The permissible operating temperature may exceed the storage temperature's lower limit. In such cases, the unit may be turned on at or above the minimal storage temperature and then used in the full range of operating temperatures after the heating phase.

<b>9.1.12. Licenses</b>	
<b>CE</b>	<ul style="list-style-type: none"> <li>EN 55022 Class A</li> <li>EN 55024, EN 61000-3-2, EN61000-3-3, EN 61000-6-2</li> <li>IEC 60950-1, EN 60950-1, UL 60950-1</li> </ul>

## 9.2. System resources - Part 1



The resources cited are reference values only. They may vary depending on system configuration. These reference values are especially useful for learning troubleshooting and the system.

Component	Interrupt	DMA channel	Setup default	Memory range (Hex.)	I/O range (Hex.)
CardBus controller (Ricoh RL5C475)	IRQ 15 per PCI routing	–	PCI/ISA PnP	0F000000 – 0F000FFF	–
Network controller (Realtek 8139)	IRQ 15 per PCI routing	–	PCI/ISA PnP	EE000000 – EE0000FF	C000 – C0FF
1 <sup>st</sup> IDE controller	IRQ 14 per PCI routing	–	PCI/ISA PnP	–	01F0 – 01F7 03F6 – 03F6 C400 – C407
Numeric coprocessor	IRQ 13	–	PCI/ISA PnP	–	00F0 – 00FF
PS/2 Analog Touch	IRQ 12	–	PCI/ISA PnP	–	0060 – 0060
USB controller	IRQ 10	–	PCI/ISA PnP	–	C800 – C81F
CMOS/real time clock	IRQ 08	–	–	–	0070 – 0073
LPT1 (only available internally)	IRQ 07	–	PCI/ISA PnP	–	0378 – 037F
Floppy disk drive	IRQ 06	2 (8-bit)	PCI/ISA PnP	–	03F2 – 03F5
SCI IRQ ACPI bus	IRQ 05	–	PCI/ISA PnP	–	
COM2	IRQ 03	–	legacy ISA	–	02F8 – 02FF
COM1	IRQ 04	–	legacy ISA	–	03F8 – 03FF
Interrupt controller	IRQ 02	–	–	–	0020 – 0021 00A0 – 00A1
Keyboard	IRQ 01	–	–	–	0060 – 0060 0064 – 0064
System timer	IRQ 00	–	–	–	0040 – 0043

### 9.3. System resources - Part 2

Component	Interrupt	DMA channel	Setup default	Memory range (Hex.)	I/O range (Hex.)
Graphic controller	–	–	–	0000C000 – 0000D400 000A0000 – 000AFFFF 000B0000 – 000BFFFF 000C0000 – 000CDFFF E0000000 – E7FFFFFF EC000000 – EC00FFFF ED000000 – ED07FFFF	03B0 – 03BB 03C0 – 03DF
DMA controller	–	4 (16 bit)	–	–	0000 – 000F 0080 – 0090 0094 – 009F 00C0 – 00DF
I/O read for ISA PnP	–	–	–	–	–
PCI bus	–	–	–	–	0CF8 – 0CFF 4000 – 407F 4080 – 40FF 5000 – 500F 6000 – 607F
system board upgrade for ACPI Bios	–	–	–	00000000 – 0009FFFF 000D0000 – 000D3FFF 000F0000 – 000F7FFF 000F8000 – 000FBFFF 000FC000 – 000FFFFFF 00100000 – 06FFFFFF 06FF0000 – 06FFFFFF FEE00000 – FEE00FFF FFFF0000 – FFFFFFFF	–
Motherboard resources	–	–	–	–	0010 – 001F 0022 – 003F 0044 – 005F 0062 – 0063 0065 – 006F 0074 – 007F 0091 – 0093 00A2 – 00BF 00E0 – 00EF 04D0 – 04D1
VIA CPU to AGP controller	–	–	–	E0000000 – E7FFFFFF EC000000 – EDFFFFFF	–
VIA Standard CPU to PCI bridge	–	–	–	E8000000 – EBFFFFFF	–
System speaker	–	–	–	–	0061 – 0061

## 9.4. Resistance of the touch screen

### 9.4.1. Resistance to chemical substances

The transparent coating of the Intelligent Instrumentations touch screen's surface is resistant to most chemical substances that are normally used at home or in the industrial sector.

As the majority of chemicals react more intensely at higher temperatures, the screen has been designed for normal room temperatures as well as extreme operating temperatures.



**Caution:** The data listed here applies exclusively to Intelligent Instrumentation's resistive touch screens.

Household chemicals	Visible effect	Visible effect
	at 29° C, 90% relative humidity (RH)	at 50° C, dry
Reaction time: 24 hours		
Coffee	none	none
Tomato sauce	none	none
Cleaning agents (liquid)	none	none
Milk	none	none
Mustard	none	slight yellow stain
Strong tea	none	none
Vinegar	none	none

*Table: Resistance of the touch screen against household chemicals*

Solvents/ Industrial chemicals	Visible effect	Visible effect
	at 29° C, 90% relative humidity (RH)	at 50° C, dry
Acetic acid	none	none
Acetone/MEK, 50/50	none	none
Brake fluid	none	none
Butyl acetate	none	none
Cellosolve acetate	none	none
Ethanol/isopropanol, 50/50	none	none
Petrol	none	none
Concentrated sulphuric acid	none	none
Petrol-based oil	none	none
Mineral oil	none	none
40% sodium hydroxide	none	Slight corrosion
111 trichlorethane	none	none
Turpentine	none	none
Vm & P Naphtha	none	none

*Table: Resistance of the touch screen against solvents and industrial chemicals*

#### 9.4.2. Pencil hardness test ASTM D 3363.74

Test scale (from softest to hardest): 6B, 5B, 4B, 3B, 2B, B, HB, F, H, 2H, 3H, 4H, 5H, 6H, 7H, 8H, 9H

##### **Adhesion:**

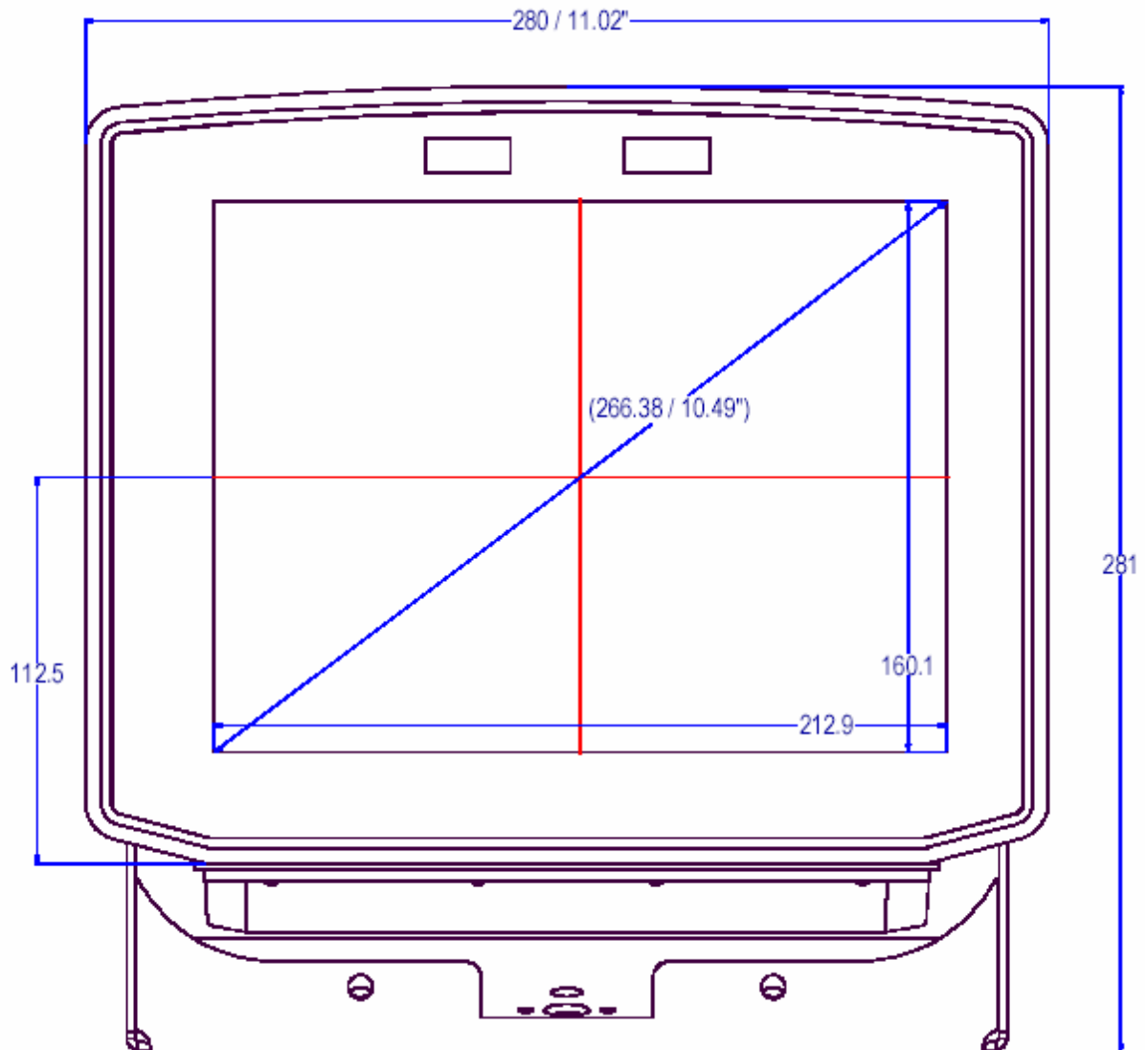
Test results: 0B = 100% delamination; 5B = no delamination

## 9.5. System dimensions

### 9.5.1. LANpoint XL 10,4" SVGA dimensions

#### 9.5.1.1. Front view

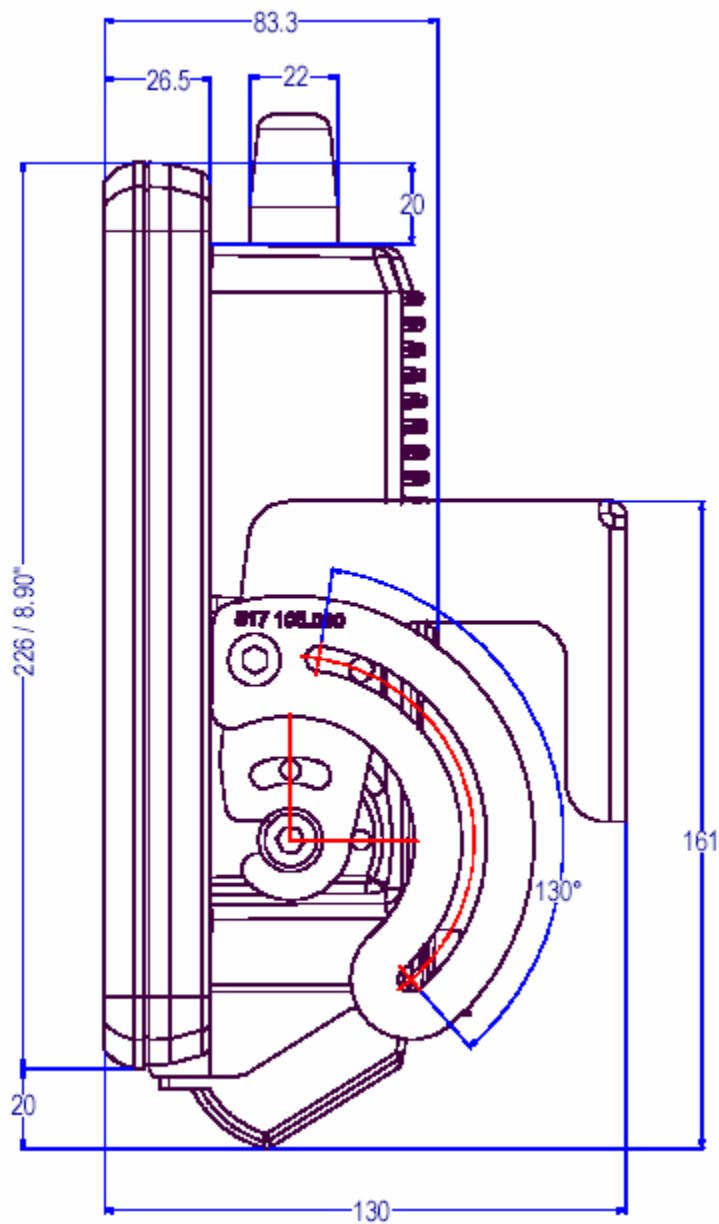
Dimensions (mm) with tilt mount:



**Figure A.1:** LANpoint XL 10,4" SVGA front view

**9.5.1.2. Side view**

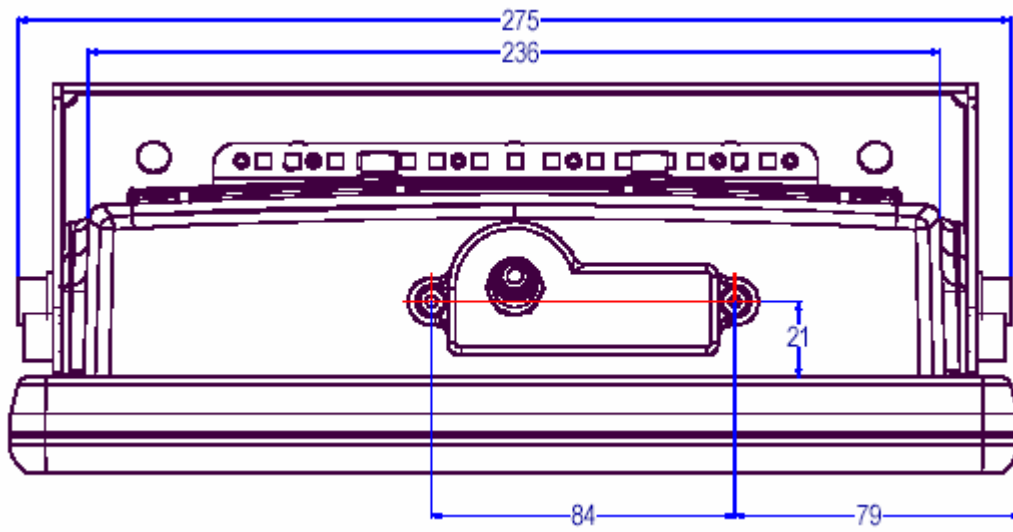
Dimensions (mm) with tilt mount:



**Figure A.2:** LANpoint XL 10,4" SVGA side view

**9.5.1.3. Top view**

Dimensions (mm) with tilt mount:

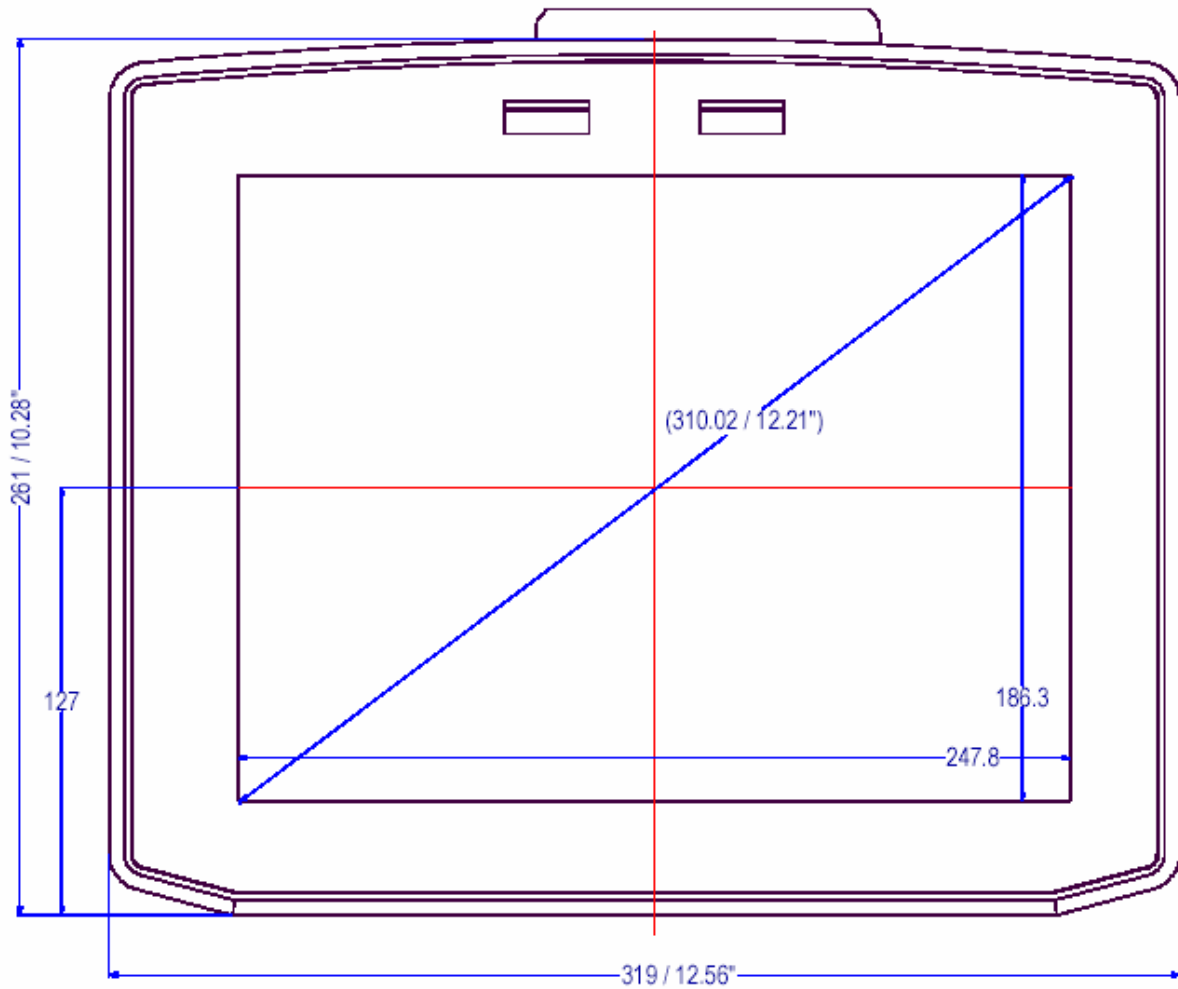


**Figure A.3:** LANpoint XL 10" SVGA top view

## 9.5.2. LANpoint XL 12,1" dimensions

### 9.5.2.1. Front view

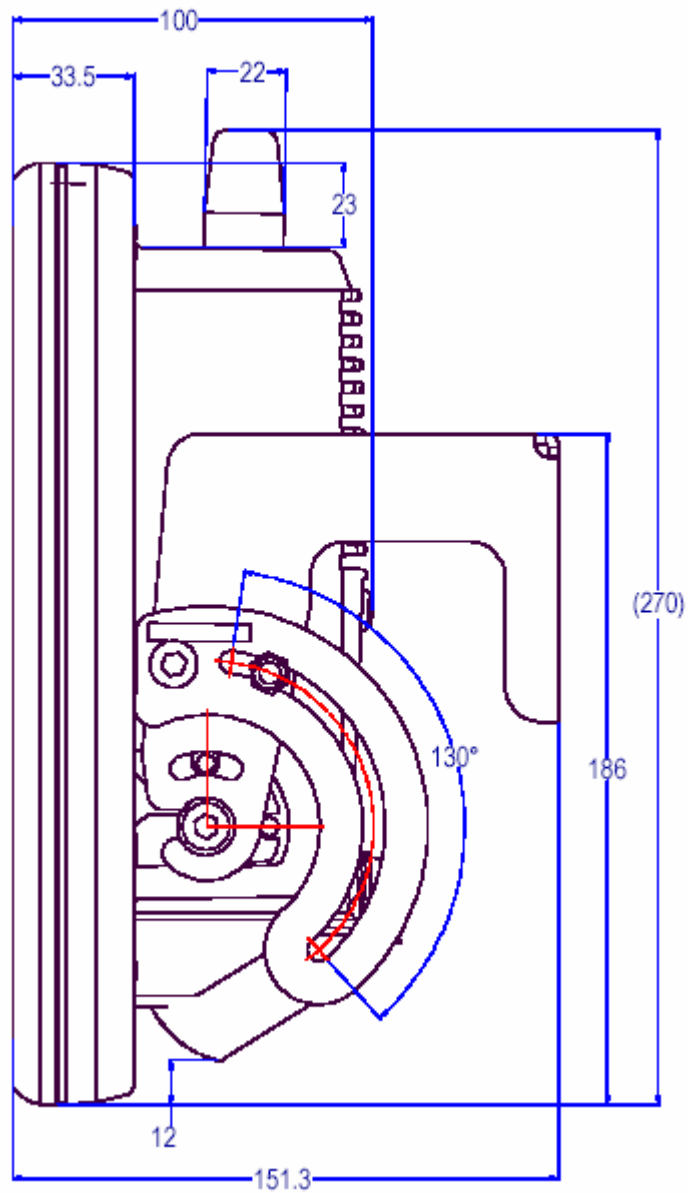
Dimensions (mm) with tilt mount:



*Figure A.4: LANpoint XL 12,1" front view*

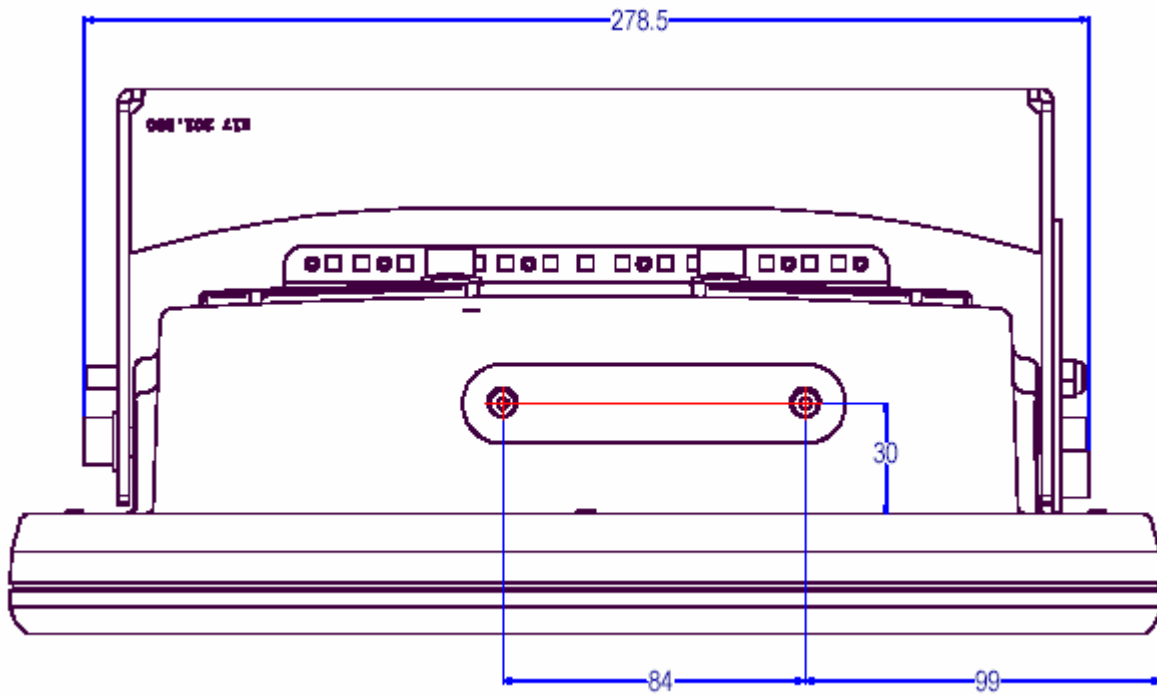
**9.5.2.2. Side view**

Dimensions (mm) with tilt mount:

**Figure A.5: LANpoint XL 12,1" side view**

**9.5.2.3. Top view**

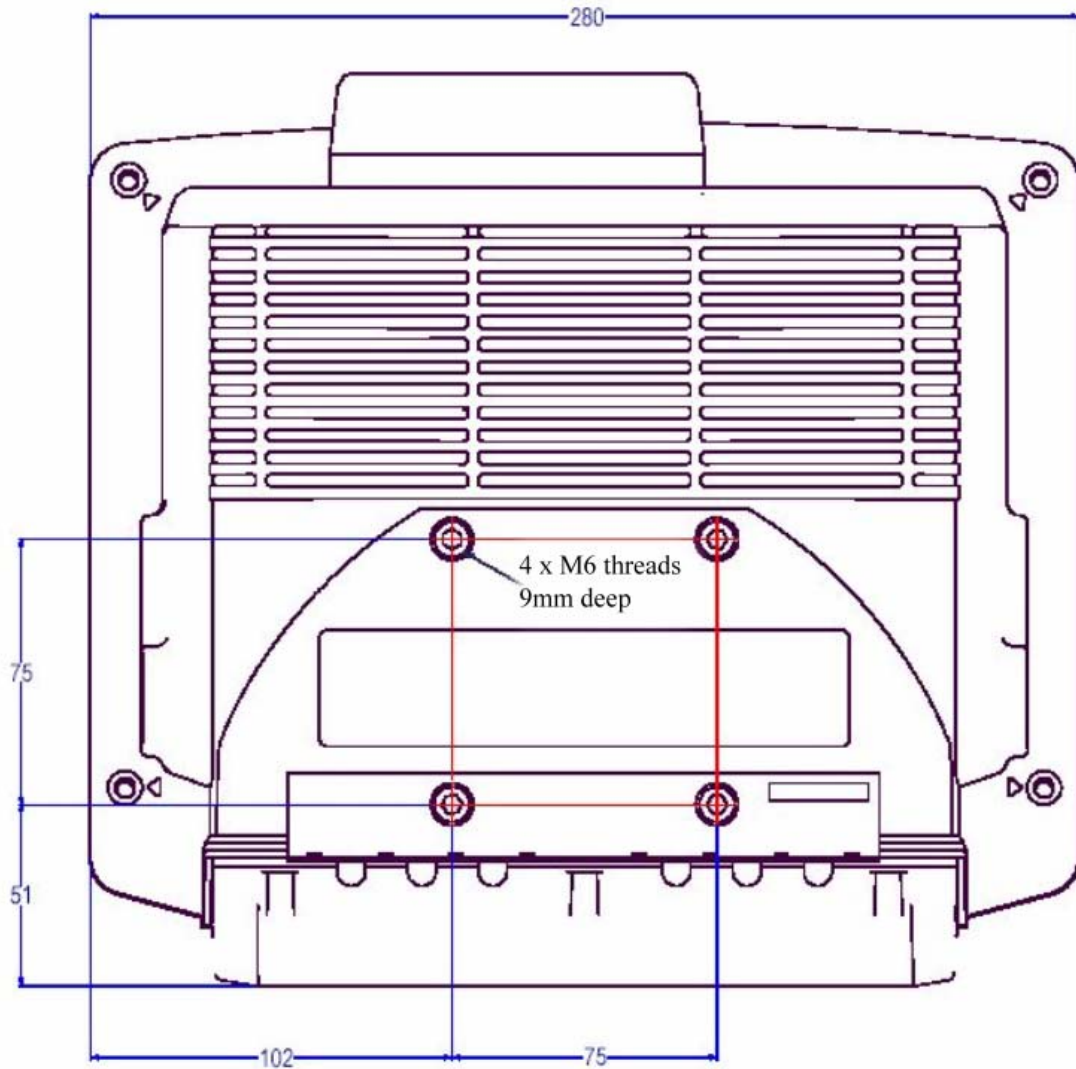
Dimensions (mm) with tilt mount:



*Figure A.6: LANpoint XL 12" top view*

## 9.6. VESA holes

This drawing indicates the LANpoint XL's VESA holes:



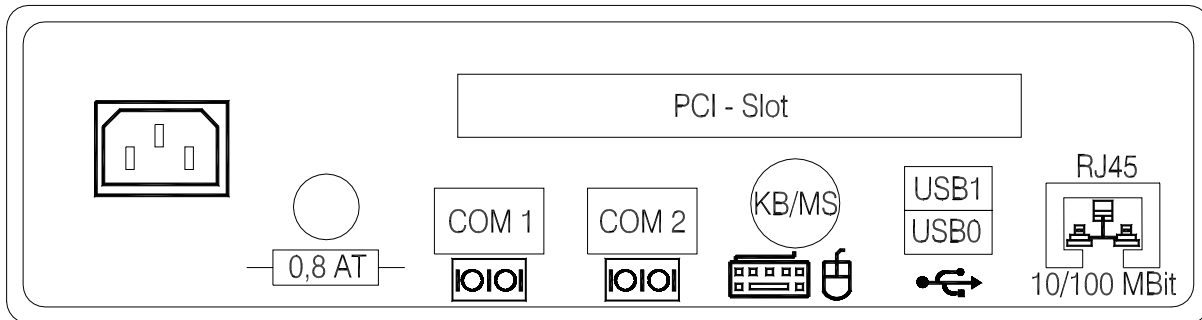
**Figure A.7:** LANpoint XL 10,1" with VESA holes

## 10. Appendix B: Pin configuration

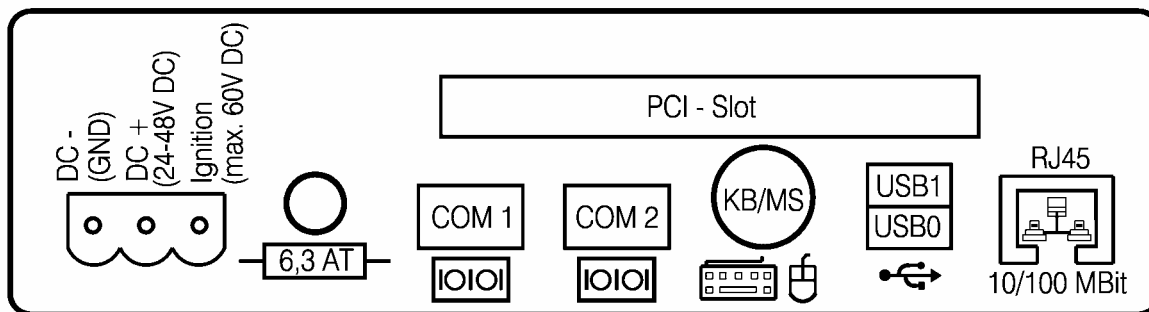
This section describes the pin configuration for all the LANpoint XL plug-in connectors.

The pin configuration is based on the Rev. 5.20 03.2003 motherboard.

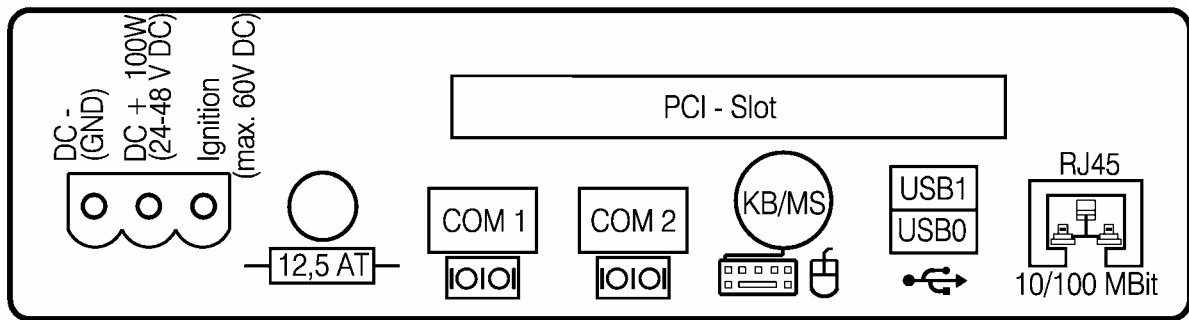
### 10.1. External connectors



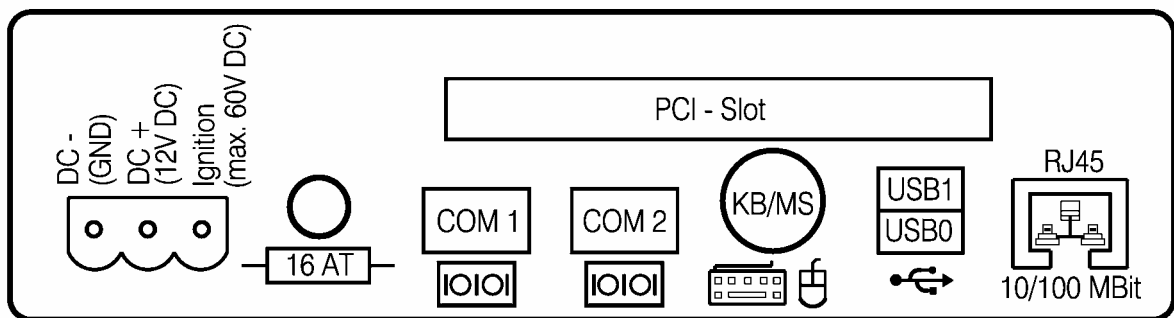
*Figure B.1: External connectors, AC version*



*Figure B.2: External connectors, 24/48 VDC 60 W version*



**Figure B.3:** External connectors, 24/48 VDC 100 W version



**Figure B.4:** External connectors, 12 VDC 100 W version

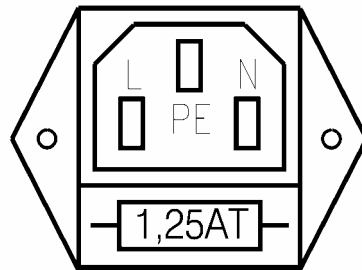
### 10.1.1. AC voltage supply connector

Version: Standard power plug (IEC 320 compliant), 3-pin.



Before operating the device, carefully read all the pages containing warnings and safety notices at the start of this manual. If you do not follow the safety instructions provided, the system may be damaged, and all present or future guarantee and liability claims will be instantly voided.

Outside view of the connector:



**Figure B.5:** Outside view of the AC power supply connector

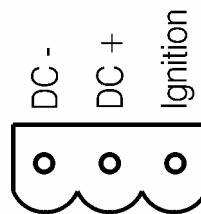
### 10.1.2. DC voltage supply connector

Version: Phoenix Combicon, 3-pin.



Before operating the unit, carefully read all the pages containing warnings and safety notices at the start of this manual. If you do not follow the safety instructions provided, the system may be damaged, and all present or future guarantee and liability claims will be instantly voided.

Outside view:



**Figure B.6:** Outside view of the DC power supply connector

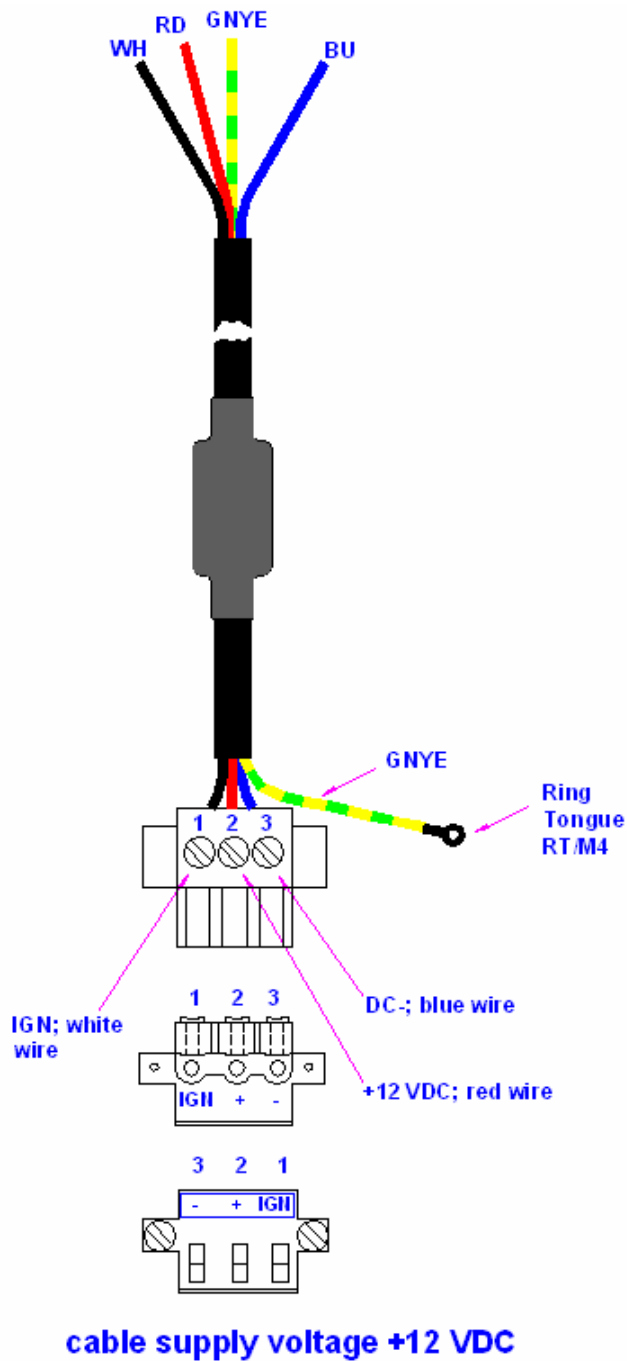


Explanation: *Ignition on* means that a control signal has to be routed to this connection (e.g., ignition of a vehicle), that matches the supply voltage level and is able to supply at least 2 W to the LANpoint XL.

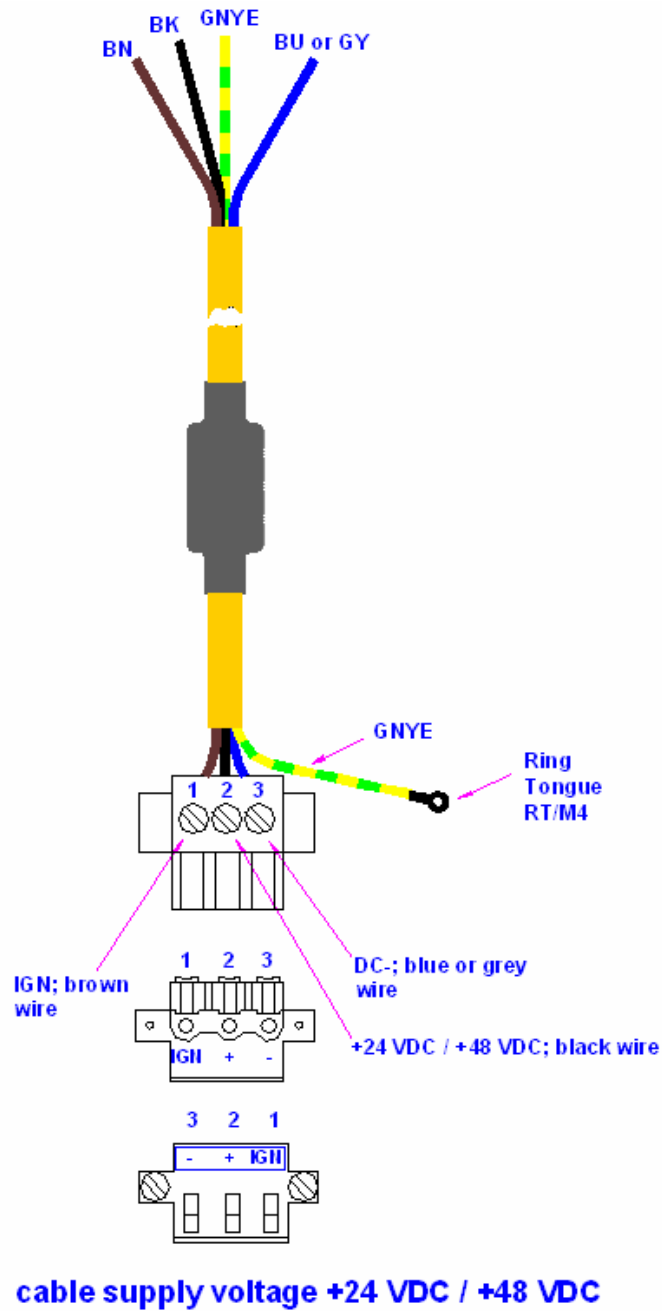
The signal reference is DC-.

**10.1.2.1. LANpoint XL supply connection**

The following diagrams show the DC device's supply connection cables.



*Figure B.7: Cable diagram of the +12 VDC device's supply connection*



**Figure B.8:** Cable diagram of the +24 / +48 VDC device's supply connection

### 10.1.3. Keyboard and Mouse

Version: Mini-DIN (PS2), 6-pin

Motherboard ref. P12

Pin	Signal
1	KBDATA
2	MSDATA
3	GND
4	+5V fused
5	KBCLOCK
6	MSCLOCK

Keyboard only or keyboard and mouse connected via a Y cable

### 10.1.4. USB

Version: 8-pin

Motherboard ref. P13

Pin	Signal
1	+5V fused
2	USB0 -
3	USB0 +
4	GND
5	+5V fused
6	USB1 -
7	USB1 +
8	GND

**10.1.5. Serial port COM1**

Version: D-SUB-D, 9-pin, MALE

Motherboard ref. P15

Pin	Signal	Name	Comment
1	DCD	Data Carrier Detect	
2	RxD	Receive Data	
3	TxD	Transmit Data	
4	DTR	Data Terminal Ready	
5	GND	Signal Ground	
6	DSR	Data Set Ready	
7	RTS	Request to Send	
8	CTS	Clear to Send	
9	RI / +5V fused / +12V fused	Ring Indicate	settable with J9

**10.1.6. Serial port COM2**

Version: D-SUB-D, 9-pin, MALE

Via adapter cable to motherboard ref. P16

**10.1.6.1. RS232 - Version (Standard)**

Pin	Signal	Name
1	DCD	Data Carrier Detect
2	RxD	Receive Data
3	TxD	Transmit Data
4	DTR	Data Terminal Ready
5	GND	Signal Ground
6	DSR	Data Set Ready
7	RTS	Request to Send
8	CTS	Clear to Send
9	RI	Ring Indicate

**10.1.6.2. RS422 - Version (Optional)**

Pin	Signal	Name
1	connected with Pin2	
2	connected with Pin1	
3	RXD-	Receive Data -
4	TXD-	Transmit Data -
5	GND	Signal Ground
6	connected with Pin7	
7	connected with Pin6	
8	RXD+	Receive Data +
9	TXD+	Transmit Data +

**10.1.6.3. RS485 - Version (Optional)**

Pin	Signal	Name
1	connected with Pin2	
2	connected with Pin1	
3	not connected	
4	RXD-/TXD-	Receive/Transmit Data -
5	GND	Signal Ground
6	connected with Pin7	
7	connected with Pin6	
8	not connected	
9	RXD+/TXD+	Receive/Transmit Data +

**10.1.7. Network connector**

Version: RJ-45, 8-pin

Motherboard ref. P14

Pin	Signal	Name
1	TxP	Transmit +
2	TxN	Transmit -
3	RxP	Receive +
4	CTTD	Transmit Center Termination
5	CTRD	Receive Center Termination
6	RxN	Receive -
7	n.c.	
8	TERM	Termination

*n.c. = not connected*

**10.1.8. CardBus connector**

Version: 68pol., MALE, options

Motherboard ref. P21, via the top slot

Pin	Signal	Pin	Signal
1	GND	35	GND
2	D3	36	CD1#
3	D4	37	D11
4	D5	38	D12
5	D6	39	D13
6	D7	40	D14
7	CE1#	41	D15
8	A10	42	CE2#
9	OE#	43	VS1#
10	A11	44	IORD#
11	A9	45	IOWR#
12	A8	46	A17
13	A13	47	A18
14	A14	48	A19
15	WE#	49	A20
16	RDY	50	A21
17	VCC	51	VCC
18	VPP1	52	VPP2
19	A16	53	A22
20	A15	54	A23
21	A12	55	A24
22	A7	56	A25
23	A6	57	VS2#
24	A5	58	RESET#
25	A4	59	WAIT#
26	A3	60	INPACK#
27	A2	61	REG#
28	A1	62	BVD2#
29	A0	63	BVD1#
30	D0	64	D8
31	D1	65	D9
32	D2	66	D10
33	WP	67	CD2#
34	GND	68	GND

## 10.2. Internal connectors, motherboard Rev. 5.10

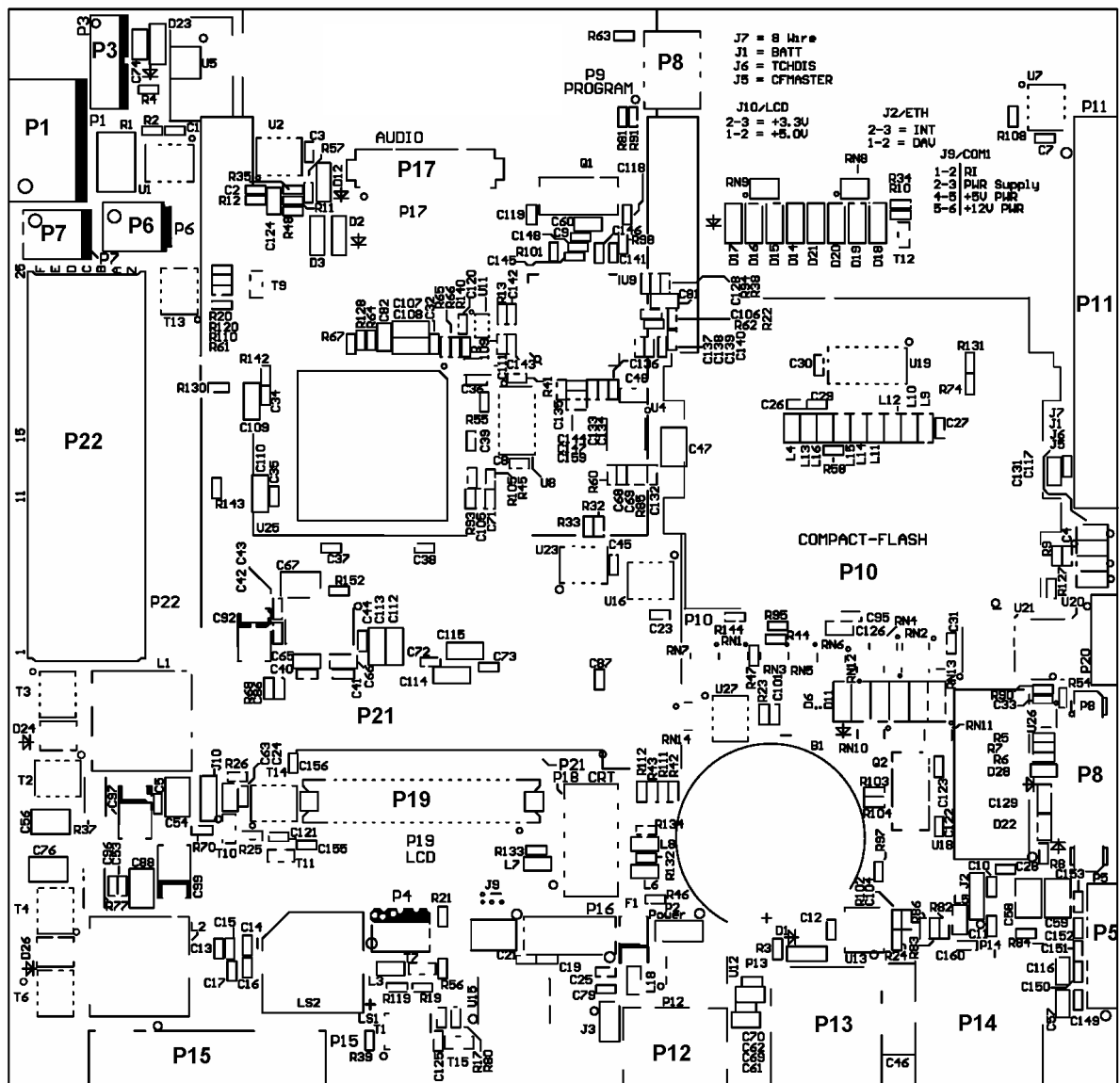


Figure B.9: Internal connectors, motherboard rev. 03.2003

### 10.2.1. Input voltage connector

Version: 1-row pin strip, 3.96 mm grid, 4-pin

Motherboard ref. P1

Pin	Signal
1	+12V
2	+12V
3	GND
4	GND

### 10.2.2. Ignition signal connector

Version: AMP Quick pin strip, 5-pin

Motherboard ref. P3

Pin	Signal
1	Ignition signal
2	DC-IN-GND
3	n. c.
4	SUPPLY-POWERDOWN
5	+12V_STANDBY

### 10.2.3. Heating power connectors

Version: pin strip, 3.96 mm grid, 2-pin

Motherboard ref. P6, P7

Pin	Signal
1	+12V
2	Heat GND

#### 10.2.4. Serial port COM2

Version: AMP MicroMatch socket strip, 10-pin

Motherboard ref. P16

Pin	Signal
1	DCD
2	DSR
3	RxD
4	RTS
5	TxD
6	CTS
7	DTR
8	RI
9	GND
10	+5V fused

#### 10.2.5. Audio interface

Version: Hirose DF13, 12-pin

Motherboard ref. P17

Pin	Signal
1	AUXAR
2	AUXAL
3	SNDR
4	SNDL
5	MIC
6	+5V
7	+5V
8	+12V
9	AGND
10	AGND
11	SPEAKER +
12	SPEAKER -

**10.2.6. IDE plug-in connector**

Version: 2-row pin strip, 2.00 mm grid, 44-pin

Motherboard ref. P11

Pin	Signal	Pin	Signal
1	/RST	2	GND
3	D7	4	D8
5	D6	6	D9
7	D5	8	D10
9	D4	10	D11
11	D3	12	D12
13	D2	14	D13
15	D1	16	D14
17	D0	18	D15
19	GND	20	key / no pin
21	/DRQ	22	GND
23	/IOW	24	GND
25	/IOR	26	GND
27	/CHRDY	28	+5V pull-up
29	/DACK	30	GND
31	IRQ	32	n.c.
33	A1	34	n.c.
35	A0	36	A2
37	/CS1	38	/CS3
39	ACTIVEHD	40	GND
41	VCC	42	VCC
43	GND	44	VCC

*n.c. = not connected*

**10.2.7. CompactFlash plug-in connector**

Version: 2-row pin base, 50-pin

Motherboard ref. P10

Pin	Signal	Pin	Signal
1	GND	2	D3
3	D4	4	D5
5	D6	6	D7
7	/CE1	8	GND
9	GND	10	GND
11	GND	12	GND
13	+5V	14	GND
15	GND	16	GND
17	GND	18	A2
19	A1	20	A0
21	D0	22	D1
23	D2	24	n.c.
25	+5V pull-up	26	+5V pull-up
27	D11	28	D12
29	D13	30	D14
31	D15	32	/CE2
33	n.c.	34	/IOR
35	/IOW	36	+5V
37	IRQ	38	+5V
39	M/S Select	40	n.c.
41	RESET	42	READY
43	/INPACK	44	/REG
45	DASP	46	DIAG
47	D8	48	D9
49	D10	50	GND

*n.c. = not connected*

**10.2.8. LCD connector**

Version: Hirose DF13, 40-pin

Motherboard ref. P19

Pin	Signal	Pin	Signal
1	GND	21	D9
2	n.c.	22	D8
3	n.c.	23	GND
4	n.c.	24	GND
5	n.c.	25	D11
6	n.c.	26	D10
7	n.c.	27	D13
8	n.c.	28	D12
9	n.c.	29	D15
10	n.c.	30	D14
11	GND	31	D17
12	GND	32	D16
13	D1	33	D19
14	D0	34	D18
15	D3	35	GND
16	D2	36	GND
17	D5	37	+3,3/5V SWI
18	D4	38	+3,3/5V SWI
19	D7	39	+3,3/5V LCD
20	D6	40	+3,3/5V LCD

**10.2.9. Front keyboard connector**

Version: FFC connector, 17-pin

Motherboard ref. P8

Pin	Signal	Pin	Signal
1	SHIFT-LED	10	SWITCH 2
2	GND	11	SWITCH 1
3	TEMP-LED	12	SWD2
4	HD-LED	13	SWD3
5	POWER-LED	14	SWITCH 0
6	SWITCH 5	15	SWD1
7	SWD0	16	SWD4
8	SWITCH 4	17	SWD5
9	SWITCH 3		

**10.2.10. Inverter connector**

Version: Hirose DF13, 12-pin

Motherboard ref. P5

Pin	Signal	Pin	Signal
1	GND	7	BKL_EN
2	VDIMM	8	GND
3	GND	9	GND
4	BKL_PWM	10	+12V
5	+5V	11	+12V
6	+5V	12	+12V

**10.2.11. Inverter connector**

Version: Hirose DF13, 8-pin

Motherboard ref. P20

Pin	Signal	Pin	Signal
1	Y-	5	X+
2	SY-	6	SX+
3	SY+	7	SX-
4	Y+	8	X-

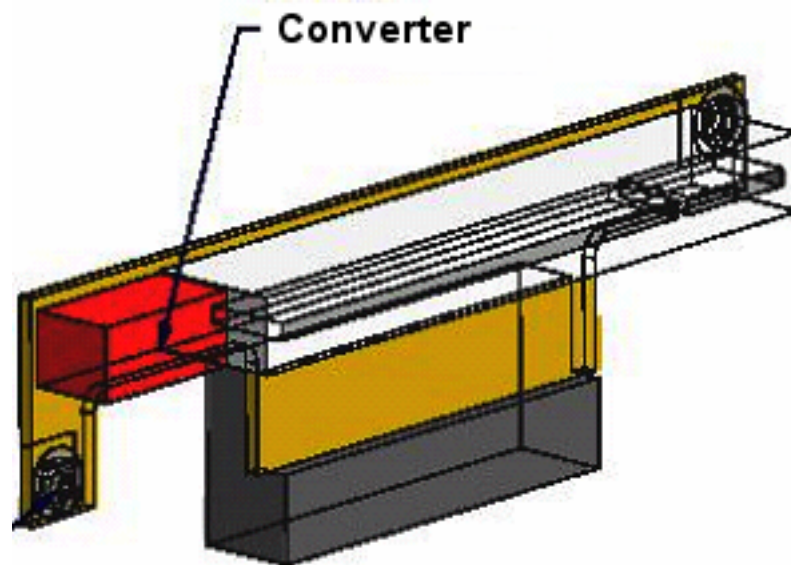
**10.2.12. Riser Card connector**

Version: CPCI pin strip B (7-row), 2 mm grid, 154-pin

Motherboard ref. P22

Row							
N o.	Z	A	B	C	D	E	F
1	GND	GND	+12V	+12V	-12V	-12V	GND
2	GND	n.c.	INTD#	INTC#	INTB#	INTA#	GND
2	GND	n.c.	+5V	+5V	+5V	+5V	GND
4	GND	PCIRST#	GND	PCICLK	+5V	+5V	GND
5	GND	GND	GND	GND	GND	PCICLK	GND
6	GND	PCICLK	GND	REQ3#	GNT3#	GND	GND
7	GND	GND	n.c.	n.c.	n.c.	n.c.	GND
8	GND	GND	GNT2#	GNT1#	REQ2#	REQ1#	GND
9	GND	GND	GND	+3,3V	+3,3V	+3,3V	GND
10	GND	AD31	AD30	AD29	AD28	AD27	GND
11	GND	AD26	AD25	AD24	C/BE3#	AD23	GND
15	GND	AD22	AD21	AD20	AD19	AD18	GND
16	GND	AD17	AD16	C/BE2#	FRAME#	IRDY#	GND
17	GND	GND	GND	+3,3V	+3,3V	GND	GND
18	GND	TRDY#	DEVSEL#	STOP#	LOCK#	SERIRQ	GND
19	GND	PERR#	PME#	SERR#	PAR	AD15	GND
20	GND	GND	GND	+3,3V	+3,3V	GND	GND
21	GND	C/BE1#	AD14	AD13	AD11	AD12	GND
22	GND	AD10	AD09	C/BE0#	AD08	AD07	GND
23	GND	GND	GND	+3,3V	+3,3V	GND	GND
24	GND	AD06	AD04	AD05	AD03	AD02	GND
25	GND	GND	AD00	AD01	+3,3V	GND	GND

### 10.3. Internal connectors, riser card



*Figure B.10: Internal connectors, riser card 1 x PCI*

**10.3.1. PCI connectors (CC)**

Version: MicroChannel (2-row), 124-pin, 5 V / 32 bit

Riser cards ref. P4, P5

-12V	B1	A1	#TRST
TCK	B2	A2	+12V
GND	B3	A3	TMS
TDO	B4	A4	TDI
+5V	B5	A5	+5V
+5V	B6	A6	#INT A
#INT B	B7	A7	#INT C
#INT D	B8	A8	+5V
#PRSNT1	B9	A9	reserved
reserved	B10	A10	+5V I/O
#PRSNT2	B11	A11	reserved
GND	B12	A12	GND
GND	B13	A13	GND
Reserved	B14	A14	reserved
GND	B15	A15	#RST
CLK	B16	A16	+5V I/O
GND	B17	A17	#GNT
#REQ	B18	A18	GND
+5V I/O	B19	A19	reserved
AD31	B20	A20	AD30
AD29	B21	A21	+3.3V
GND	B22	A22	AD28
AD27	B23	A23	AD26
AD25	B24	A24	GND
+3.3V	B25	A25	AD24
C/#BE3	B26	A26	IDSEL
AD23	B27	A27	+3.3V
GND	B28	A28	AD22
AD21	B29	A29	AD20
AD19	B30	A30	GND
+3.3V	B31	A31	AD18
AD17	B32	A32	AD16
C/#BE2	B33	A33	+3.3V
GND	B34	A34	#FRAME
#IRDY	B35	A35	GND
+3.3V	B36	A36	#TRDY
#DEVSEL	B37	A37	GND
GND	B38	A38	#STOP
#LOCK	B39	A39	+3.3V
#PERR	B40	A40	SDONE
+3.3V	B41	A41	#SBO
#SERR	B42	A42	GND

+3.3V	B43	A43	PAR
C/#BE1	B44	A44	AD15
AD14	B45	A45	+3.3V
GND	B46	A46	AD13
AD12	B47	A47	AD11
AD10	B48	A48	GND
GND	B49	A49	AD09
mechanical code	B50	A50	mechanical code
mechanical code	B51	A51	mechanical code
AD08	B52	A52	C/#BE0
AD07	B53	A53	+3.3V
+3.3V	B54	A54	AD06
AD05	B55	A55	AD04
AD03	B56	A56	GND
GND	B57	A57	AD02
AD01	B58	A58	AD00
+5V I/O	B59	A59	+5V I/O
#ACK64	B60	A60	#REQ64
+5V	B61	A61	+5V
+5V	B62	A62	+5V

# 11. Appendix C: Jumpers

## 11.1. Warnings

For the operation and settings of the hardware configuration described above, the jumper positions do not need to be changed.



Changing the jumper positions can impair the function of the LANpoint XL or destroy the unit! if the jumper settings are changed, Intelligent Instrumentation is no longer liable for warranty claims!

## 11.2. Standard jumper settings



The default jumper settings are marked “ \* “. Take note of the visual representation of jumpers:



Jumper closed



Jumper open

### 11.3.Jumper layout view, motherboard

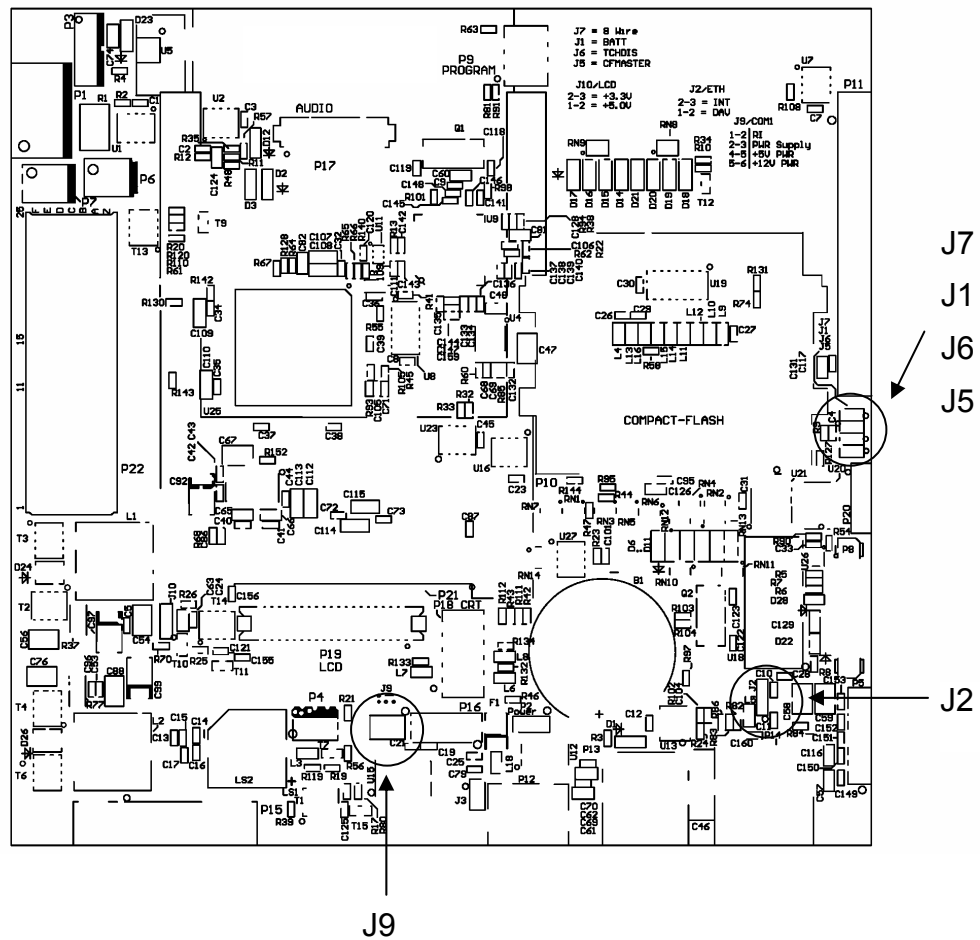


Figure C.1: Jumper layout, motherboard Rev. 5.20 03.2003

### 11.3.1. Touch configuration

Version: 1-row pin strip, 2 mm grid, 2-pin

Motherboard ref. J7

Jumper		Function
1	2	<b>8-wire touch controller</b>
1	2	<b>4-wire touch controller *</b>

\*) factory setting

### 11.3.2. Battery

Version: 1-row pin strip, 2 mm grid, 2-pin

Motherboard ref. J1

Jumper		Function
1	2	<b>RTC/CMOS RAM, battery buffered *</b>
1	2	<b>RTC/CMOS reset</b>

\*) factory setting

### 11.3.3. Touch enable

Version: 1-row pin strip, 2 mm grid, 2-pin

Motherboard ref. J6

Jumper		Function
1	2	<b>Touch deactivated</b>
1	2	<b>Touch activated *</b>

\*) factory setting

**11.3.4. CompactFlash configuration**

Version: 1-row pin strip, 2 mm grid, 2-pin

Motherboard ref. J5

Jumper		Function
1	2	CompactFlash is Master *
1	2	CompactFlash is Slave

\*) factory setting

**11.3.5. COM1 configuration**

Version: 2-row pin strip, 2.00 mm grid, 6-pin

Motherboard ref. J9

Jumper			Function
3	2	1	Pin9 is RI
6	5	4	not required

Jumper			Function
3	2	1	Pin9 is voltage supply *
6	5	4	+5 V on Pin9 *

\*) factory setting

Jumper			Function
3	2	1	Pin9 is voltage supply
6	5	4	+12 V on Pin9

### 11.3.6. Ethernet configuration

Version: 1-row pin strip, 2.00 mm grid, 3-pin

Motherboard ref. J2

Jumper			Function
1	2	3	Davicom ETH controller *
1	2	3	Intel ETH controller

\*) factory setting

### 11.3.7. LCD configuration

Version: 1-row pin strip, 2.00 mm grid, 3-pin

Motherboard ref. J10

Jumper			Function
1	2	3	+5.0 V LCD supply
1	2	3	+3.3 V LCD supply *


\*) factory setting


### 11.3.8. External shield connection

via screws

## 12. Appendix D: Tools

### 12.1.Warnings

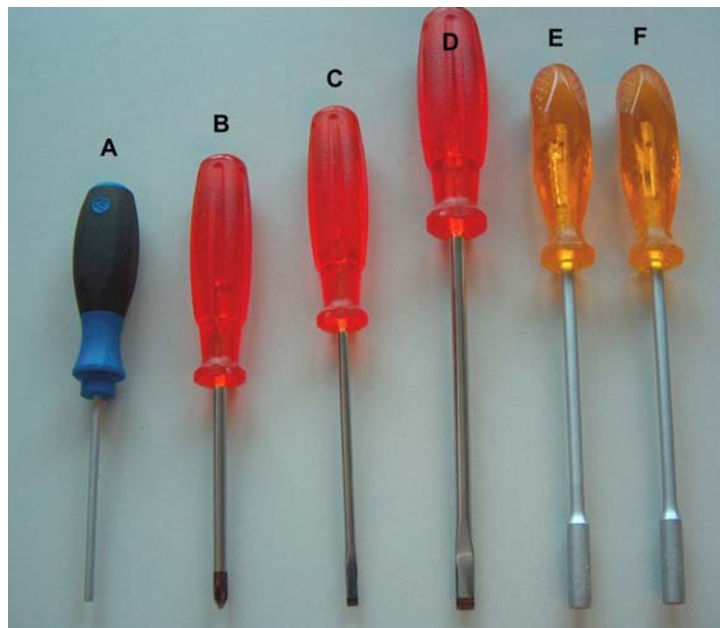
	<p>If you want to add extensions to the unit, carefully read the safety instructions provided at the start of this manual.</p>
	<p>The LANpoint XL may only be opened for the purposes of adding or exchanging modules. Only qualified electrical or electronics engineers or persons trained by Intelligent Instrumentation are authorized to do this.</p>
	<p>Prior to opening the unit, make sure that the operating system has been shut down correctly and that the unit is disconnected from the power supply.</p>

	<p>Observe the relevant accident prevention regulations when using tools of any kind.</p>
	<p>To avoid damaging or destroying the unit, be extremely careful when opening it (carefully read the safety instructions at the start of this manual)!</p>

## 12.2.LANpoint XL Toolkit

The following tools are required to assemble/disassemble the LANpoint XL:

- A = Hexagonal screwdriver, 3 mm
- B = Phillips screwdriver, size 1
- C = Screwdriver, size 2
- D = Screwdriver, size 4
- E = Socket wrench, 5 mm
- F = Socket wrench, 5.5 mm



*Figure D.1: LANpoint XL toolkit*

### Closing the device



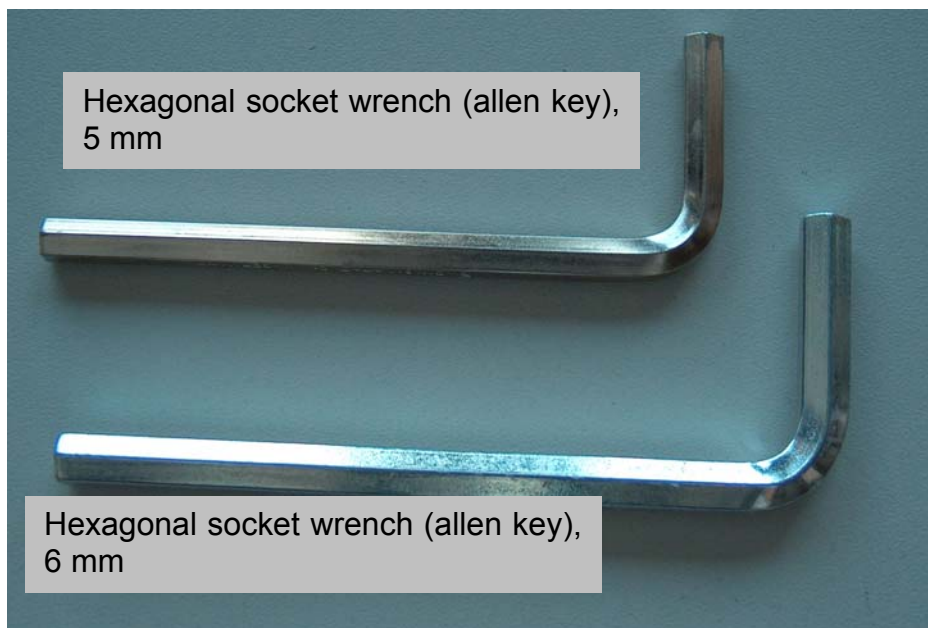
The front bezel is attached to the base unit using hexagonal screws (M5 x 20 with an inside diameter of 3 mm). In all devices, these screws must be retightened with a torque wrench. Retighten all the hexagonal screws in a **cross-wise** pattern to the following **torque**: LANpoint XL 10,4": 3Nm, LANpoint XL 12,1": 4 Nm.

Tighten both screws in the protective cap and antenna cap to a torque of 2 Nm.

### 12.3. Mounting bracket toolkit

The tools shown in *Figure D.1* are required to adjust the LANpoint XL mounting bracket:

- A 5 mm / 6 mm hexagonal socket wrench (allen key) is required for mounting and adjusting the **Fixed Mounting Bracket**.
- A 6 mm hexagonal socket wrench (allen key) is required for mounting and adjusting the **Mobile Mounting Bracket**.



*Figure D.2: Mounting bracket toolkit*

## 13. Appendix E: Common mistakes in usage

### 13.1. Power supply

The LANpoint XL is available with an integrated, electrically isolated AC or DC power supply.

- Do not connect LANpoint XL devices that have a DC power supply to an AC power source!
- Do not connect LANpoint XL devices that have an AC power supply to a DC power source!

### 13.2. Powering up/powering down

- Please note that the function of the LANpoint XL's power button varies depending on the configuration of the device (depending on the power supply and integrated automatic switch-off). See chapter 5: *Initial operation/Operating controls*.
- Only disconnect the computer from the power supply after the computer has been properly shut down and switched off. Otherwise file errors may occur on the storage device (in operating systems that have no activated write protection filter).

### 13.3. Cable cover

- The supplied cable cover for the external ports must be installed prior to using the LANpoint XL. In order to comply with protection class IP65, please use the optionally available IP65 assembly kit from Intelligent Instrumentation.

## 13.4. Installation

- Only use suitable mounting brackets and screws.
- Ensure that ball-and-socket bases and fixing brackets are securely fastened.
- Follow the instructions carefully when attaching all outgoing cables to the strain relief bar.
- The antenna cap of the wireless card has a purely protective function. Do not use it as a handle when turning the terminal.
- All fastening bows and mounting parts supplied by Intelligent Instrumentation are only intended for use in the mounting of terminals and peripheral devices and must not be used for other purposes.
- Installation conditions can vary greatly, leading to operating states where an optimisation of the mounting process is required. See chapter 3 of this manual, *Installation options*.
- When mounting peripheral devices, follow the manufacturer's instructions. This is particularly important when welding or drilling on supporting parts.
- To avoid any accidents, when mounting peripheral devices, ensure that the field of vision is not unduly restricted in any way. Observe the accident prevention regulations.

## 13.5. Mobile vehicle applications

- Never connect a 12 VDC device to a 24/48 VDC vehicle!
- Never connect a 24/48 VDC device to a 12 VDC vehicle!
- Never connect a 12/24/48 VDC device to vehicles with more than a 60 VDC voltage.
- Ensure that supply lines are fused correctly (see chapter 3: *Power supply /DC power supply*).
- Lay the supply cable in such a manner so that it will not get crushed or frayed.
- Read the labeling on the cable and take care not to connect the supply cable the wrong way round.
- Cut the supply cable as short as possible. This avoids tangled cables and improves the quality of the power supply.
- Observe the vehicle manufacturer's instructions for connecting additional loads, for instance, in conjunction with an emergency shut-off switch.
- Connect the supply cable to a suitable place. Ensure that the connecting cable has an adequate cross section and ampacity at the connection point.

## 13.6. Using the touch screen

- Please do not use sharp or abrasive objects on the LANpoint XL's touch screen.
- Do not use abrasive cleansers to clean the front of the device. The best results are obtained using a damp, non-abrasive cloth with any commercially-available window cleaner that does not contain ammonia. Apply the window cleaner to the cloth instead of spraying it directly onto the touch screen surface.

## 13.7. Use/storage in extreme temperatures

Please observe the LANpoint XL's maximum operating and storage temperatures.

Display	Operating temperature [°C]	Operating temperature with heating [°C]
10.4" VGA	0 to +50	-30 to +50
10.4" SVGA	0 to +50	-30 to +50
12.1" SVGA	0 to +50	-30 to +50
12.1" XGA	0 to +50	-30 to +50

Display	Storage temperature [°C]
10.4" VGA	-35 to +65
10.4" SVGA	-20 to +60
12.1" SVGA	-25 to +60
12.1" XGA	-20 to +65

## 13.8. Disposal/environment

- Dispose system components and other supplied components according to the legislation in force in your country and, whenever possible, in an environmentally friendly way.

## 14. Appendix F: Return packing slip

Return packing slip (please fill in once per return shipment):

Company	
Street	
Postal code, town	
Contact	
Phone number	

Type(s) of unit(s) returned:


Serial number(s) of the unit(s) returned:


The units were not returned, as they are currently being used. However, the following parts are missing:

Unit was already damaged on delivery (please enclose a copy of the delivery note)

Delivery was incomplete

Missing parts:

--

The following error occurs when operating the unit:

--

Separate error report is enclosed

# Index

- 30 AT fuse ..... 16
- Abbreviations ..... 5
- AC /DC power pack ..... 124
- AC power pack ..... 3, 15
- AC power supply internal ..... 77
- AC voltage supply connector ..... 95
- Accessing Shared Directories ..... 53
- ActiveSync 3.8 ..... 53
- ADC/MDC connection ..... 76
- ADC/MDC interface ..... 76
- ADC/MDC properties ..... 76
- Additional loads ..... 125
- Alternating current power pack ..... 15
- Ambient conditions at the point of installation  
..... VII
- Ambient temperature ..... VII, 80
- Ampacity ..... 126
- Analog touch connection ..... 75
- Analog touch controller ..... 2, 75
- Analog touch screens ..... 75
- Area of application ..... VII, 1
- Assembly equipment ..... 6
- Audio interface ..... 106
- Automatic switch-off ..... 3, 30, 67
- Automatic switch-off and heating ..... 65
- Autorun Feature ..... 55
- Autostart ..... 55
- AWDFLASH.EXE ..... 49
- Back light ..... 28
- Barcode scanners ..... 61
- Battery ..... 18
- Battery change ..... XV
- BIOS ..... 2, 32, 73
- BIOS boot messages ..... 33
- BIOS hotkeys ..... 47
- BIOS setup ..... 32, 35
- BIOS setup pages ..... 35
- BIOS setup screens ..... 35
- BIOS system check ..... 33
- BIOS system configuration ..... 34
- BIOS update ..... 48
- BIOS, general ..... 32
- BIOS, loading the standard settings ..... 47
- BOOTCEPC ..... 50
- BOOTCEPC.PCX ..... 50
- Brightness control ..... 27
- Brightness control, manual ..... 28
- Bussman ..... 79
- Cable connections ..... XIII
- Cable cover ..... 19, 21, 23
- Cable diagrams ..... 97
- Cable duct ..... 23
- Cable labelling ..... 125
- Cable ties ..... 21, 22
- Cables ..... 22, 125
- Cache ..... 73
- Cardbus ..... 76
- CardBus connector ..... 103
- Cardbus controller ..... 76
- Cardbus slot ..... 76
- CE ..... 80
- Centre of gravity ..... 10
- Change IP ..... 51
- Chemical substances ..... 84
- Chipset ..... 73
- Circuit breaker ..... 15, 16, 25
- Class A ..... XVII
- CMOS Setup ..... 35
- Cold start ..... 47
- COM1 ..... 100
- COM1 options ..... 59
- COM1, as a power supply ..... 59
- COM2 ..... 100, 106
- COM2 options ..... 60
- COM2, RS422/485 ..... 60
- CompactFlash plug-in connector ..... 108
- Computer Name ..... 53
- Configuration ..... VIII
- Configuring the TCP/IP Parameters ..... 51
- Connecting cables ..... 17, 18
- Connector bay ..... 18
- Converters ..... 18
- Cooling ..... 14
- Cooling air ..... VII, 14
- Cooling concept ..... VII, 14
- Cover hood of the wireless card ..... 125
- CPU ..... 73
- Creating a shortcut on the desktop ..... 55
- Data cables ..... IX
- DC power pack ..... 3, 16, 124
- DC power supply, internal ..... 77
- DC use ..... 16
- DC voltage supply connector ..... 96
- DC+ - connecting cables ..... 16
- De-installation ..... XII
- Depth-wise adjustment ..... 8
- Determining natural frequencies ..... 13
- Device description ..... 1
- Device model ..... X, 77
- DHCP ..... 51
- Dimensions ..... 86
- Disconnecter ..... VIII
- Disk drive ..... 19
- Display ..... 24
- Display and temperature ..... 80
- Display lighting ..... 27
- DNS ..... 51
- Elastomer springs ..... 8, 11
- Electromagnetic compatibility ..... XVII
- Elu ..... 79
- eMbedded Tools 4.0 ..... 53
- Emergency shut-off switch ..... 125
- EN Licenses ..... 80
- Environmental conditions ..... 80
- Equipment ..... 2

ESD protected area.....	XVI	LANpoint XL toolkit.....	121
Example for dimensioning an elastic bearing..	8	Large electrical loads.....	18
Excitation frequency.....	8	LCD / CRT interface.....	75
External connectors.....	93	LCD connector.....	109
External devices – connecting/discon.....	19	LEDs.....	28
Extreme temperatures.....	126	Licenses.....	80
Face attachment.....	121	Life-support systems.....	VII
FCC regulations.....	XVII	Lithium battery.....	XV
File errors.....	124	Littelfuse.....	79
File Transfer Methods.....	53	Logic ground.....	17
Floppy disk drive.....	73	MACHINE.key.....	50
Forklift applications.....	17	Maintenance.....	VI, 31
Forklift frame.....	17	Manual.....	1
Forklift motors.....	18	Mechanical.....	72
Frame (vehicle).....	17	Mechanical dynamic loading.....	7
Fresh air.....	VII	Memory expansion.....	2
Front.....	XIII	Metal splinters.....	XII
Front attachment.....	XIV	Mistakes in usage.....	124
Front controls (extended).....	29	<b>Model range</b> .....	XI
Front controls (standard).....	28	Module extension.....	XVI
Front keyboard.....	110	Moisture.....	XII
Fuse.....	IX, XV, 16	Motherboard.....	XVI, 73
Ground bolt.....	18	Motherboard battery.....	XV
Heat.....	14	Motherboard, jumper layout.....	116
Heating.....	3, 30, 65	Mounting bracket.....	6, 8
Heating power connectors.....	105	Mounting bracket toolkit.....	123
Hexagonal screws.....	XIV, 121	Mounting the device.....	6
IDE interface.....	73	Mouse.....	58, 74, 99
IDE plug-in connector.....	107	MPCCOM.....	70
Ignition.....	65, 96	Multiple power sources.....	18
Ignition connecting cables.....	16	Natural frequencies.....	13
Ignition signal.....	25	Natural frequency range for forklift trucks.....	8
Ignition signal connector.....	105	Natural oscillations.....	7
Image quality deterioration.....	XII, 31	Neck collar screws.....	23
<b>Initial operation</b> .....	VIII, 25	net use.....	53
Input voltage connector.....	105	Network.....	76
Installation.....	VI, VIII, XII	Network connection.....	19, 76
Installation environment.....	VII	Network connector.....	102
Installing components.....	XV	Network controller.....	2, 76
Internal connectors, motherboard.....	104	nk.bin.....	50
Internal connectors, riser card.....	112	Nominal current.....	77
Internal temperature.....	67	Opening seal.....	23
Inverter connector.....	110	Opening the device.....	XIII
IP65.....	21, 124	Operating controls.....	26
Jumpers.....	115	Operating states.....	30
Jumpers, battery.....	117	Operating system.....	VIII
Jumpers, COM1 configuration.....	118	Operating system, installation.....	51
Jumpers, CompactFlash configuration.....	118	Operating temperature.....	80
Jumpers, ethernet configuration.....	119	Oscillations.....	7
Jumpers, external shield connection.....	119	Output (power).....	16
Jumpers, LCD configuration.....	119	Overheating.....	VII, 14
Jumpers, standard settings.....	115	Packaging.....	4
Jumpers, touch configuration.....	117	PCI connectors.....	113
Jumpers, touch enable.....	117	PCI POST adapter.....	46
Jumpers, warnings.....	115	PCI slot.....	73
Keyboard.....	19, 56, 74, 99	Peripheral devices.....	IX, 3, 18, 19, 78
<b>LAN</b> .....	51	Peripheral devices, external.....	56
LANpoint XL 10,4 and 12,1 models.....	2	Phoenix Contact plug.....	16
LANpoint XL 10,4 SVGA dimensions.....	86	Pin configuration.....	93
LANpoint XL 12,1 dimensions.....	89	Plug-in cards.....	3, 63, 73

POST (Power On Self Test) .....	46	Siba .....	79
POST codes .....	46	SMALL keyboard.....	57
Power button.....	124	Software .....	74
Power consumption .....	78	Software wedge .....	61
Power failures .....	3	<b>Special keys</b> .....	29
Power for peripheral devices .....	78	START.bat .....	55
Power On Self Test.....	46	Start-up problems.....	18
Power supply .....	IX, XII, 15, 19, 77	Storage temperature .....	80
Power supply cables.....	VIII	Strain relief rail .....	4, 21, 22
Power supply connector .....	VIII	Subnet.....	51
Power supply fuses.....	79	Supply cable.....	125
Power switch.....	15	Supply connection.....	97
Power up.....	25	Supply voltage lines .....	15
Powering down .....	124	Surface.....	XII
Powering up.....	25, 124	Surrounding conditions .....	67
Printers .....	18, 60	System chipset.....	2
Protection class .....	VII	System dimensions .....	86
Protection class IP65.....	XIII, XIV, 21, 124	System equipment .....	72
Protective film .....	24	System overloads.....	XVI
PS/2-Wedges.....	18	System resources .....	82, 83
Pword.exe.....	55	System tuned to a high frequency .....	7
Qualified personnel.....	VIII	System tuned to a low frequency.....	8
Radio interference .....	XVII	Technical specifications .....	72
RAM.....	73	Temperature.....	80
RAM mount elements .....	6	Temperature inside the unit, excessively	
Real-time clock .....	73	high/low .....	28
<b>REGFLUSH.EXE</b> .....	51, 52	Temperature sensor.....	30
Remote File Viewer .....	53	Temperature warning, hot.....	30
Remote Manager .....	53	text editor .....	55
Repairs .....	X	Tools.....	120
Resources.....	59	Torque wrench .....	XIII, XIV, 121
Retighten screws .....	23	Total spring constant.....	8
Return packing slip .....	127	Touch screen .....	XII, 75
Returning your device.....	5	Touch screen resistance.....	84
Ring tongue .....	18	Touch screen, cleaning.....	31
Riser Card.....	63	Touch screen, pencil hardness test .....	85
Riser Card connector.....	111	Touch screen, surface.....	31
Riser card with 1x PCI .....	64	Type plate on back of unit.....	X
Risk of injury .....	VIII	UPS battery .....	3
Rotating bases .....	6	USB .....	74, 99
RS232 mouse .....	58	USB mouse .....	58
RS-422.....	60	Validity of test marks .....	XIV
RS-485.....	60	Vehicle applications .....	17
RTL81391 .....	51	Vehicle chassis .....	12, 18
Rubber buffers .....	8, 11	Vehicle steering wheels .....	6
Safety notices .....	VI	VGA controller.....	2, 75
Safety regulations .....	VI	Vibration .....	80
Scanner .....	61	Vibration insulation.....	7
Schurter .....	79	Visual Studio.NET 2003.....	53
Scope of delivery .....	4	Voltage drops .....	3
Scratching.....	XII	Wall mounts .....	6
Seal.....	XIII	Warm start.....	47
SELV electric .....	16	Waste heat .....	VII, 14
Serial interfaces .....	59, 74	wedgece.exe .....	61
Serial interfaces, tips & tricks .....	62	<b>Week of manufacture</b> .....	XI
<b>Serial number</b> .....	XI	Wickmann .....	79
Shared Directory Name .....	53	Windows CE.NET .....	50
Shield ground.....	17	Windows CE.NET 4.2 .....	50
Shock.....	80	Windows CE.NET registry.....	55
shortcut.....	55	Wireless card .....	125

**WLAN** ..... 51  
Y-cable ..... 58